

Cautions and Warnings

1. This product must be installed in accordance with the applicable installation code by a person familiar with the construction and operation of the product and hazards involved.
2. Power must be OFF when connecting the fixture. "hot plugging" devices will damage the LED source.
3. The light engine is low voltage and must be connected to the Confetti Driver Box. **DO NOT CONNECT LIGHT ENGINE TO MAINS AC POWER.**
4. Polarity is important. Black must be connected to black and red connected to red.
5. LEDs should be protected from dust and debris during installation and maintenance.
6. **DO NOT** daisy chain devices. Each light engine must be connected to a Confetti Driver Box port - 4 ports per Confetti Driver Box.
7. Confetti is IC (insulated ceiling) rated but **NOT** for spray foam insulation.
8. Not designed for use as temporary lighting.
9. Do not allow Paint or any Primer to contaminate the receiver.

What you will need

1. Components in the box
2. Confetti Counter Bore Hole Saw (CFCBHS) - available for purchase - contact your local sales representative for ordering instructions.
3. Connectors compatible with 22ga. AWG, lever nut recommended
4. (2) #6 drywall screws $\leq 1"$ in length.
5. Construction adhesive.
6. Painter's tape.

What is in the Box?

- A. (1) Flangeless trim and receiver
- B. (1) Light engine with wire quick connects and harness with flying leads (Note: See Datasheet for remote driver wire run guidance.)

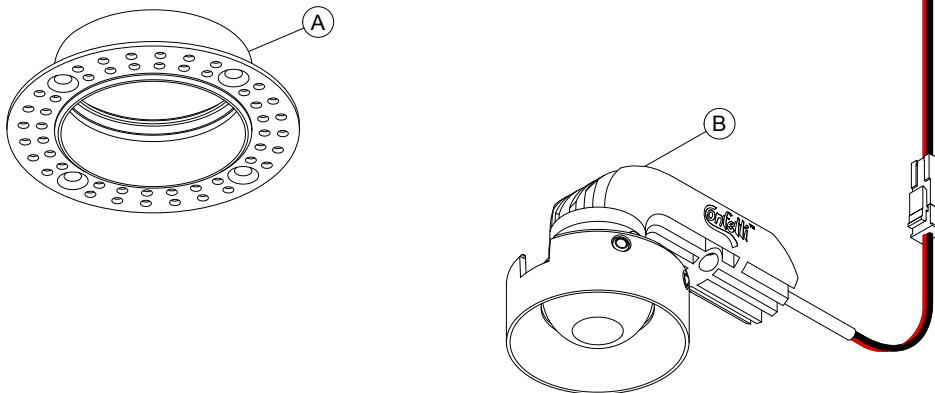

** LED'S SHOULD BE PROTECTED FROM DUST AND DEBRIS DURING INSTALLATION AND MAINTENANCE

[Click here to read full Care and Maintenance](#)

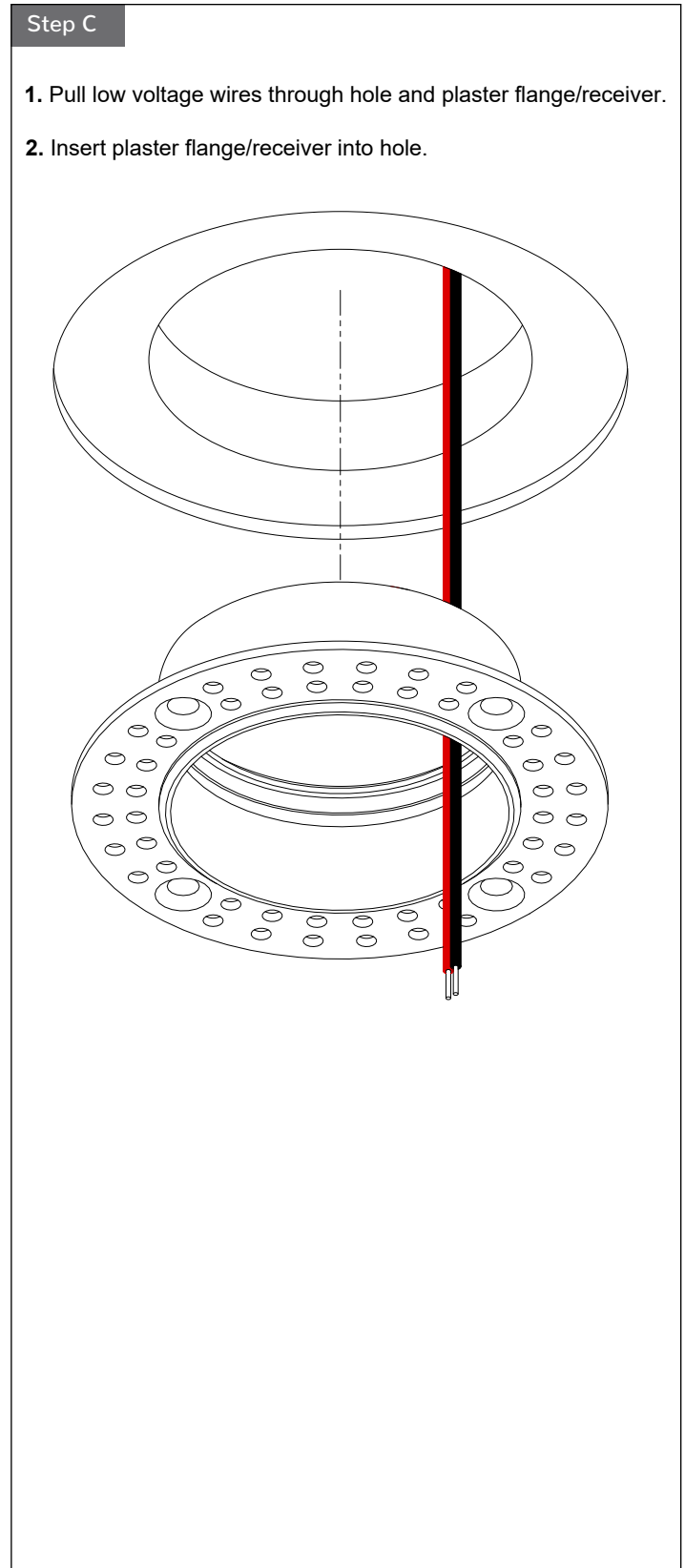
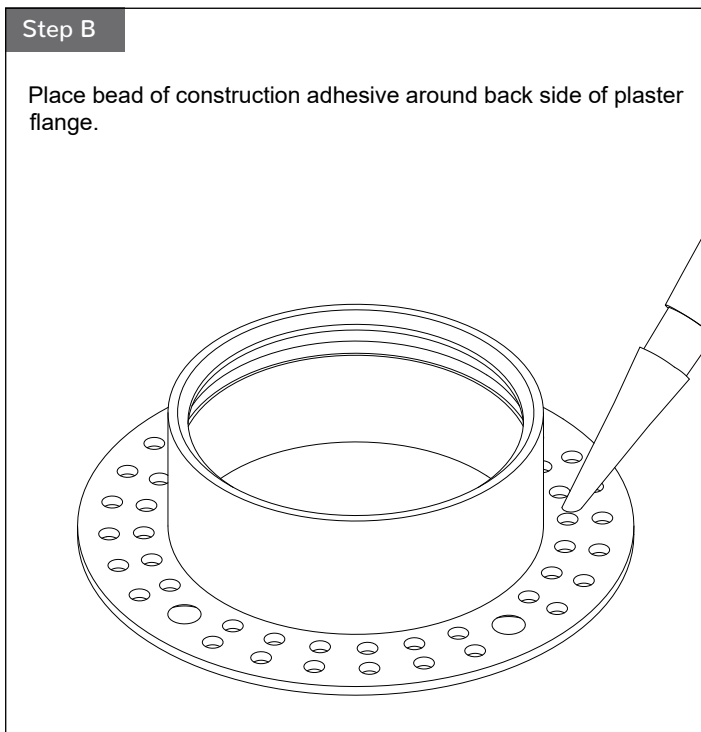
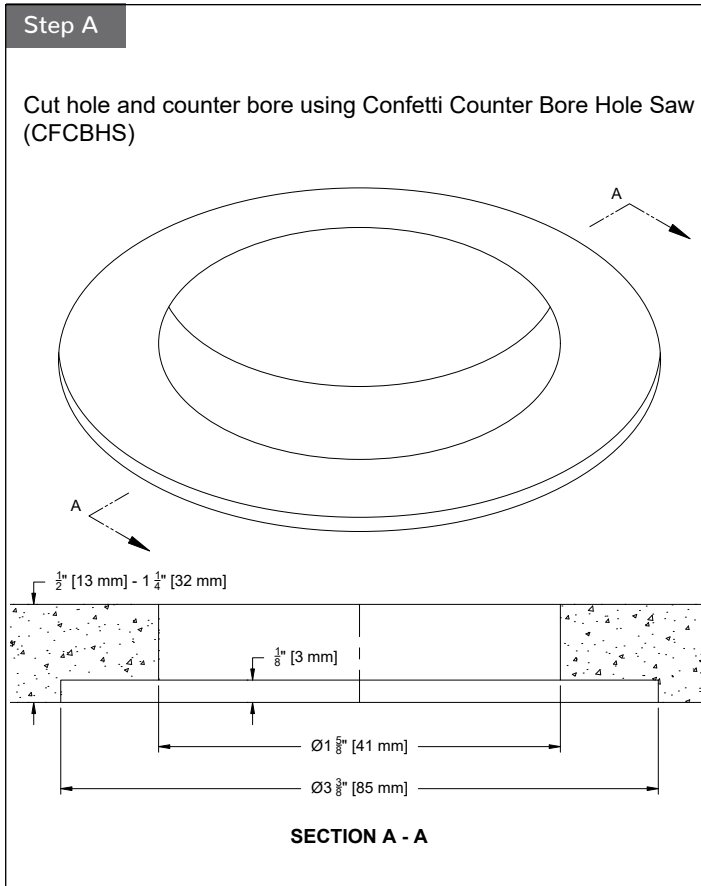

Installation Instructions Confetti 1" - Rd Flangeless Trim Adjustable Eyeball

for CF1D-RA-Z

Step D

1. Fasten plaster flange/receiver to drywall with two #6 drywall screws.
2. Remove any extra construction adhesive protruding below surface of plaster flange/receiver.

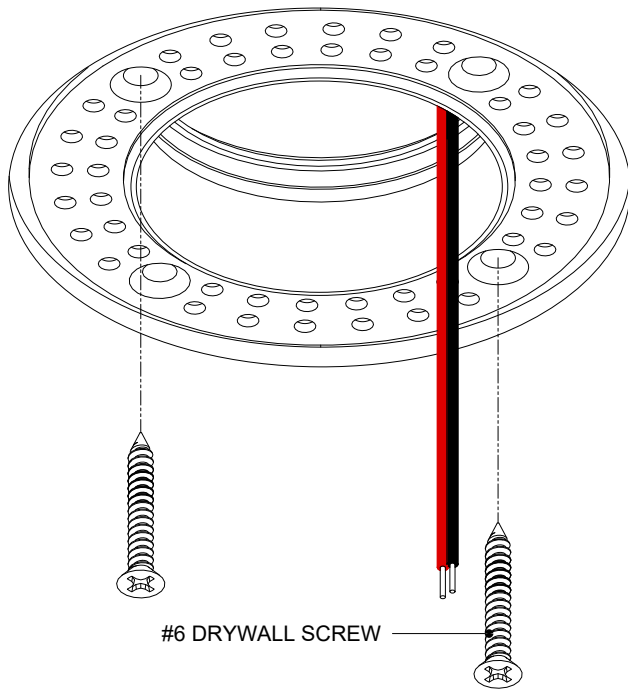

Step F

Mask inside surface of plaster flange with painter's tape to protect inside surface from debris, dirt and paint.

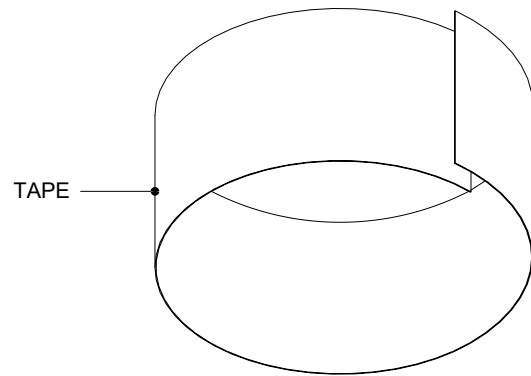
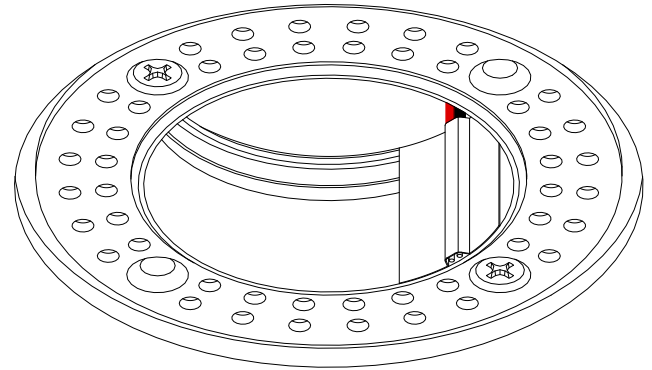

Step E

Secure low voltage wires to inside of plaster flange/receiver with tape. Allowing access after ceiling is finished.

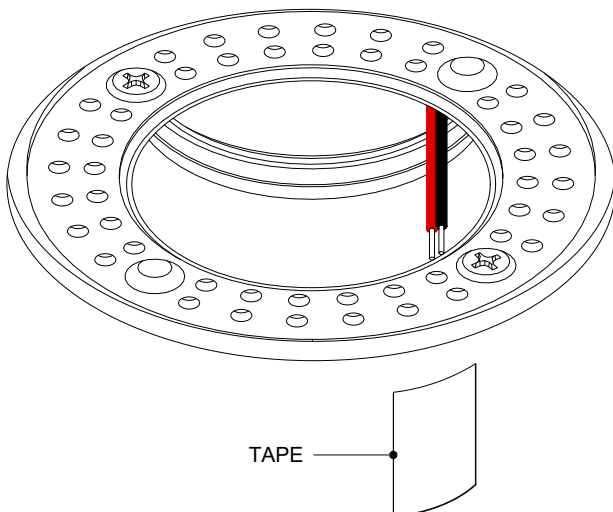

Step G

1. Apply and finish joint compound over plaster flange to create flush continuous surface.
2. Paint ceiling ensuring no paint enters inside of plaster flange/receiver.

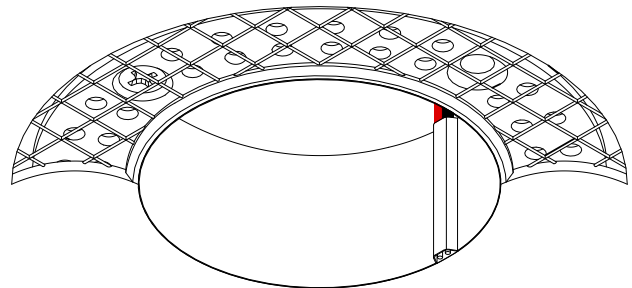

Installation Instructions Confetti 1" - Rd Flangeless Trim Adjustable Eyeball

for CF1D-RA-Z

Step H

1. Remove tape from inside plaster flange/receiver ensuring no contaminants or residue are inside receiver.
2. Pull low voltage wire through plaster flange/receiver hole.
3. Connect leads from light engine of their respective leads with connectors. ASSURE RED (+) IS CONNECTED TO RED AND BLACK (-) IS CONNECTED TO BLACK.

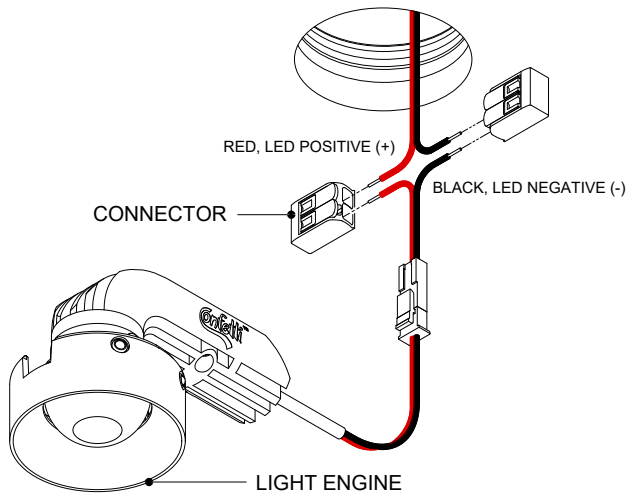

Step J

To remove light engine, insert finger into 'eyeball' hole and pull down to disengage ball plungers from receiver. Repeat step I to reinstall light engine.

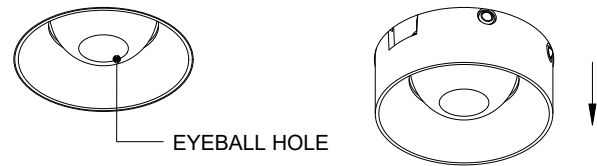

Step I

Insert the light engine into the flange/receiver. Assure the light engine is "square" with trim/receiver and apply even pressure with both thumbs until the light engine snaps into place.

