

# Installation Instructions

## Confetti 1" Pendant Round- Flanged Trim

for CF1D-RP-F

### Cautions and Warnings

1. This product must be installed in accordance with the applicable installation code by a person familiar with the construction and operation of the product and hazards involved.
2. Power must be OFF when connecting the fixture. "hot plugging" devices will damage the LED source.
3. The light engine is low voltage and must be connected to the Confetti Driver Box. **DO NOT CONNECT LIGHT ENGINE TO MAINS AC POWER.**
4. Polarity is important. Black must be connected to black and red connected to red.
5. LEDs should be protected from dust and debris during installation and maintenance.
6. **DO NOT** daisy chain devices. Each light engine must be connected to a Confetti Driver Box port - 4 ports per Confetti Driver Box.
7. Confetti is IC (insulated ceiling) rated but **NOT** for spray foam insulation.
8. Not designed for use as temporary lighting.
9. Do not allow Paint or any Primer to contaminate the receiver.

### What you will need

1. Components in the box
2. 1-5/8" diameter hole saw
3. Connectors compatible with 22ga. AWG, lever nut recommended

### What is in the Box?

**A.** (1) Flanged trim and receiver with wing springs.

**B.** (1) Light engine assembly with wire quick connects and harness and flying leads  
(Note: See Datasheet for remote driver wire run guidance.)

**C.** 2mm hex wrench.

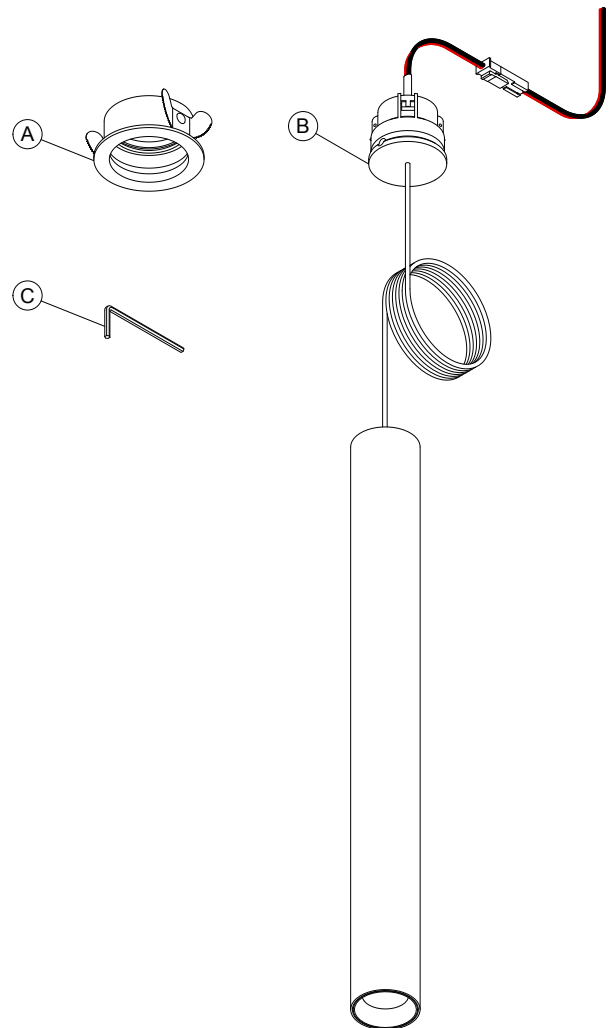

**\*\* LED'S SHOULD BE PROTECTED FROM DUST AND DEBRIS DURING INSTALLATION AND MAINTENANCE**

[Click here to read full Care and Maintenance](#)

# Installation Instructions Confetti 1" Pendant Round- Flanged Trim

for CF1D-RP-F

## Step A

Cut  $\text{Ø}1\text{-}5/8"$  [41 mm] hole with hole saw.

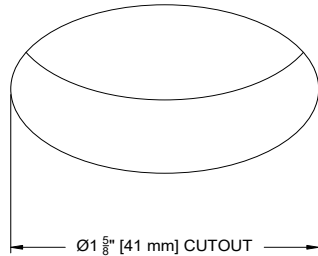

## Step C

Connect leads from light engine to their respective leads with connectors. ENSURE RED (+) IS CONNECTED TO RED AND BLACK (-) IS CONNECTED TO BLACK.

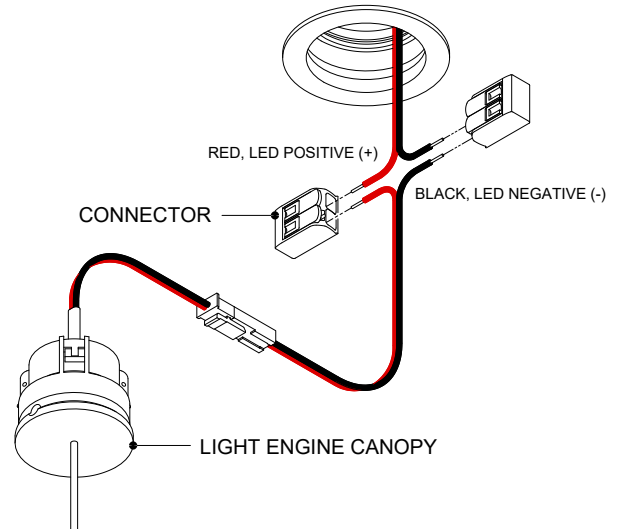

## Step B

1. Pull low voltage wire through hole and trim.
2. Depress wing spring with fingers. (Caution: wing springs are sharp)
3. Insert trim/receiver into cutout allowing wing springs to deploy during insertion.

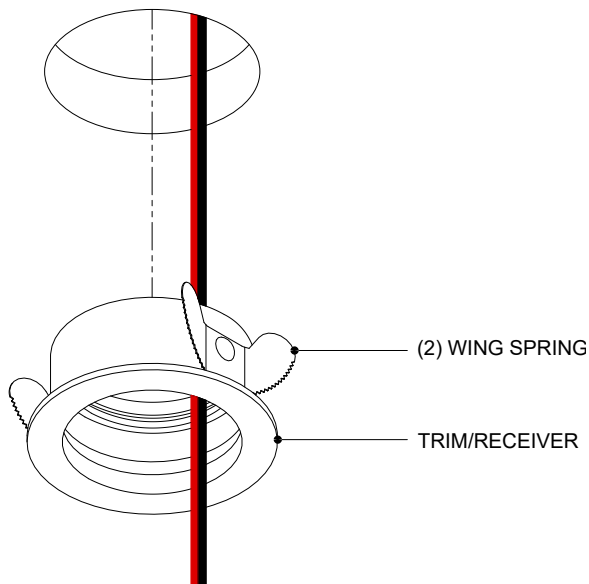

## Step D

Adjust cable to length

1. Loosen hex screw on the side of canopy attachment with included 2mm hex wrench.
2. Move light engine canopy up or down coaxial cable to desired length and tighten hex screw. Do not over-tighten set screw. Doing so may break or short cable.
3. Feed excess wire up through hole. It is not recommended that the pendant cable is trimmed to length.

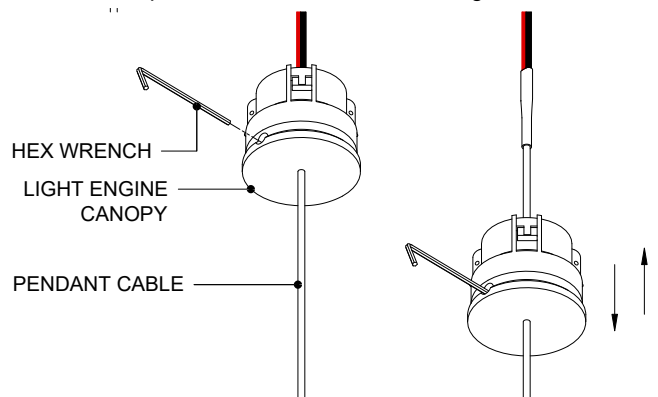

# Installation Instructions

## Confetti 1" Pendant Round- Flanged Trim

for CF1D-RP-F

### Step E

1. Ensure plastic attachment clips are in the down position.
2. Insert the light engine canopy into the plaster flange/receiver. Assure the light engine is "square" with trim/receiver and apply even pressure with both thumbs until the light engine canopy snaps into place.

Note: Assure device is in first 'snap' position. Pushing past to the second 'snap' position will deploy clips to replacement mode and allow fixture to drop from receiver.

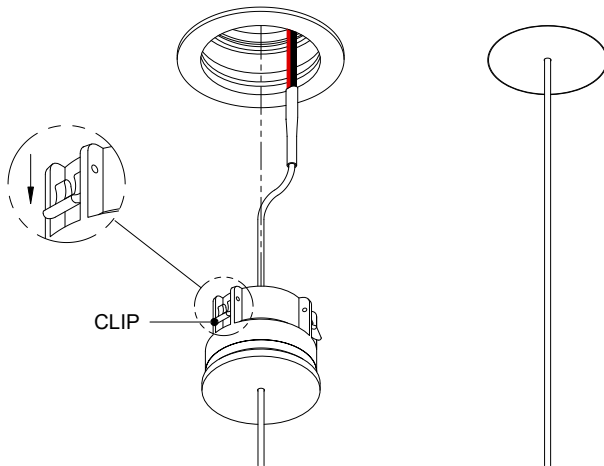

### Step F

#### Adjust cable to length

1. Loosen hex screw on the side of canopy attachment with included 2mm hex wrench.
2. Move light engine canopy up or down coaxial cable to desired length and tighten hex screw. Do not over-tighten set screw. Doing so may break or short cable.
3. Feed excess wire up through hole. It is not recommended that the pendant cable is trimmed to length.

