

Installation Instructions Confetti Round Flanged

for CF1 type – D-RA-F (Fixed Round Adjustable Eyeball)

Cautions and Warnings

1. This product must be installed in accordance with the applicable installation code by a person familiar with the construction and operation of the product and hazards involved.
2. Power must be OFF when connecting the fixture. "hot plugging" devices will damage the LED source.
3. The light engine is low voltage and must be connected to the Confetti Driver Box. **DO NOT CONNECT LIGHT ENGINE TO MAINS AC POWER.**
4. Polarity is important. Black must be connected to black and red connected to red.
5. LEDs should be protected from dust and debris during installation and maintenance.
6. **DO NOT** daisy chain devices. Each light engine must be connected to a Confetti Driver Box port - 4 ports per Confetti Driver Box.
7. Confetti is IC (insulated ceiling) rated but **NOT** for spray foam insulation.
8. Not designed for use as temporary lighting.
9. Do not allow Paint or any Primer to contaminate the receiver.

What you will need

1. Components in the box
2. 2-1/4" diameter hole saw
3. Connectors compatible with 22ga. AWG, lever nut recommended

What is in the Box?

- A. (1) Flanged trim and receiver with wing springs
- B. (1) Light engine with wire quick connects and harness with flying leads (Note: See Datasheet for remote driver wire run guidance.)

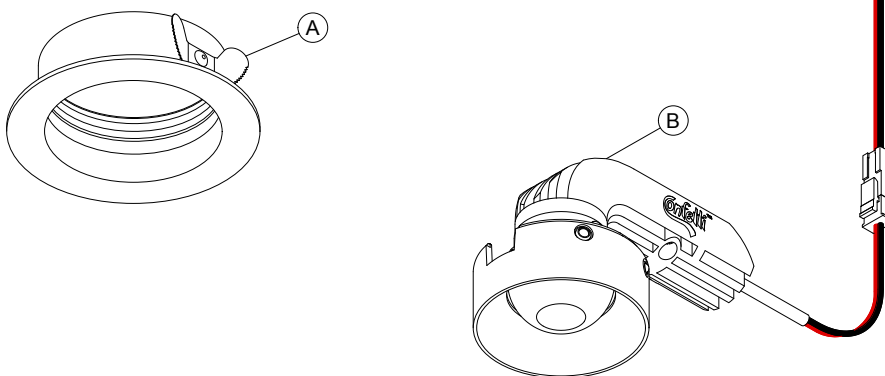

**** LED'S SHOULD BE PROTECTED FROM DUST AND DEBRIS DURING INSTALLATION AND MAINTENANCE**

[Click here to read full Care and Maintenance](#)

Installation Instructions Confetti Round Flanged

for CF1 type – D-RA-F (Fixed Round Adjustable Eyeball)

Step A

Cut Ø2-1/4" [57 mm] hole with hole saw.

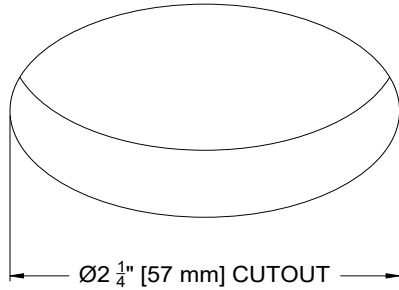

Step C

Connect leads from light engine to their respective leads with connectors. ASSURE RED (+) IS CONNECTED TO RED AND BLACK (-) IS CONNECTED TO BLACK.

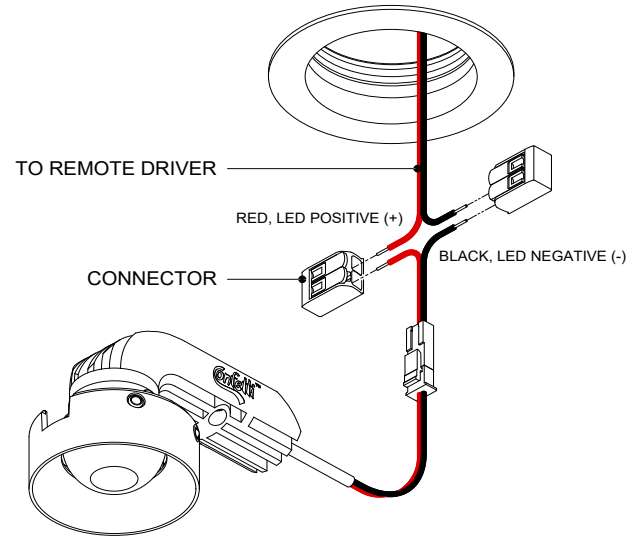

Step B

1. Pull low voltage wire through hole and trim.
2. Depress wing spring with fingers. (Caution: wing springs are sharp)
3. Insert trim/receiver into cutout allowing wing springs to deploy during insertion.

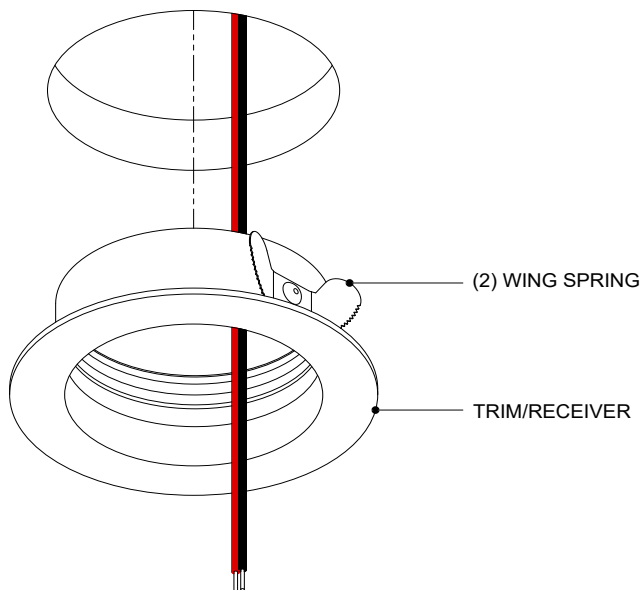

Step D

Insert the light engine into the flange/receiver. Assure the light engine is "square" with trim/receiver and apply even pressure with both thumbs until the light engine snaps into place.

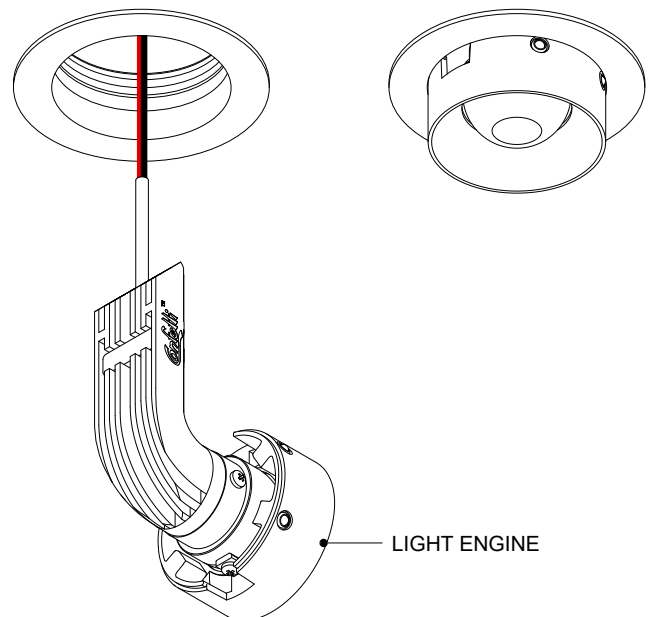

Installation Instructions

Confetti Round Flanged

for CF1 type – D-RA-F (Fixed Round Adjustable Eyeball)

Step E

To remove light engine, insert finger into 'eyeball' hole and pull down to disengage ball plungers from receiver. Repeat step D to reinstall light engine.

