

Installation Instructions

Grazefall - 2" Linear Lensed Wall Grazer - Surface Mount

for GZ2L-SM-FB & GZ2L-SM-RB

Cautions and Warnings

1. This product must be installed in accordance with the applicable installation code by a licensed electrician familiar with the construction and operation of the product and hazards involved.
2. Power must be OFF when connecting the fixture. "hot plugging" the light engine and driver will damage the LED source.
3. The light engine is low voltage and is factory wired to the driver DO NOT CONNECT LIGHT ENGINE TO MAINS AC POWER.
4. LEDs should be protected from dust and debris during installation and maintenance.
5. Polarity is important. Black must be connected to black and red connected to red.
6. Not designed for use as temporary lighting.

Step B

Cut 5" [127 mm] x 1 - 1/2" [38 mm] rectangular opening in ceiling to allow for flush mount of fixture. Refer to submittal drawing for location and quantity of wiring access plate.

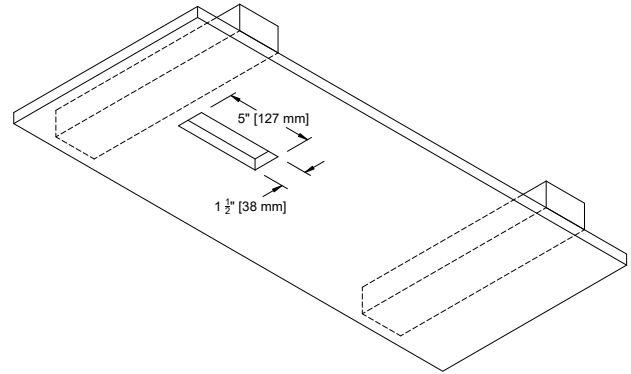

Step A

Install blocking tied to framing at mounting points behind surface fixture is being mounted to at locations as indicated in submittal drawing. Refer to submittal drawing for location and quantity of mounting holes.

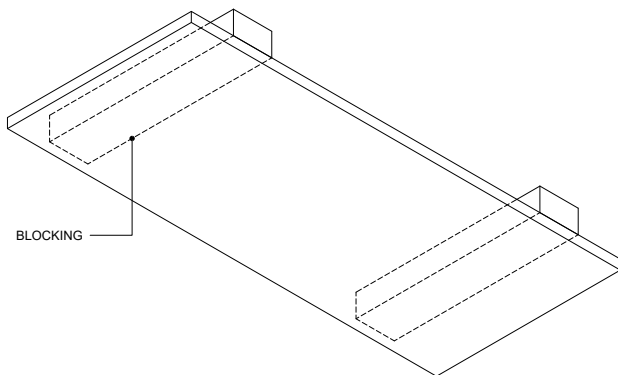

Step C

Prior to installing the housing on surface. Connect power to fixture through wiring access plate by removing two screws that fasten the plate to the housing. Replace wiring access plate.

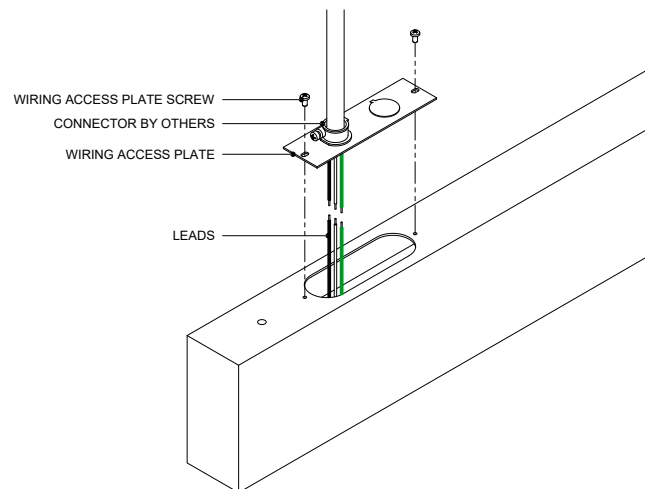

**** LED'S SHOULD BE PROTECTED FROM DUST AND DEBRIS DURING INSTALLATION AND MAINTENANCE**

[Click here to read full Care and Maintenance](#)

Installation Instructions

Grazefall - 2" Linear Lensed Wall Grazer - Surface Mount

for GZ2L-SM-FB & GZ2L-SM-RB

Step D

Mount fixture to surface with #8 wood screws or fasteners suitable for blocking material used (by others) through bushing into blocking. Taking care not to damage LED board around pass through holes.

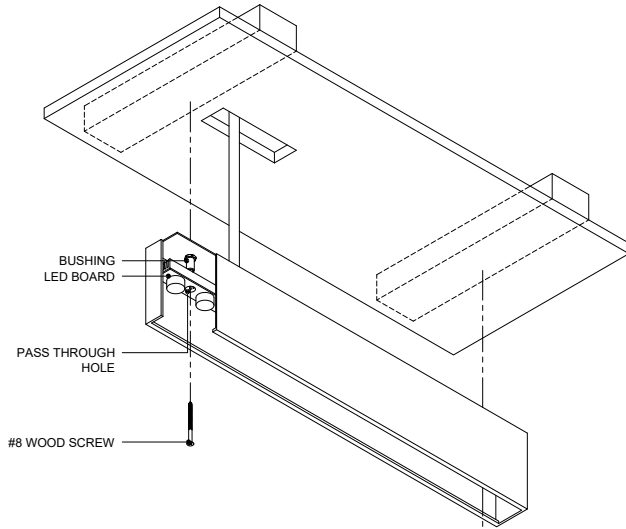

Step F

Reconnect LED/driver assembly to line voltage connector installed. Align LED/driver assembly with opening in housing. Install assembly so that pins align and catch holes in the interior latches.

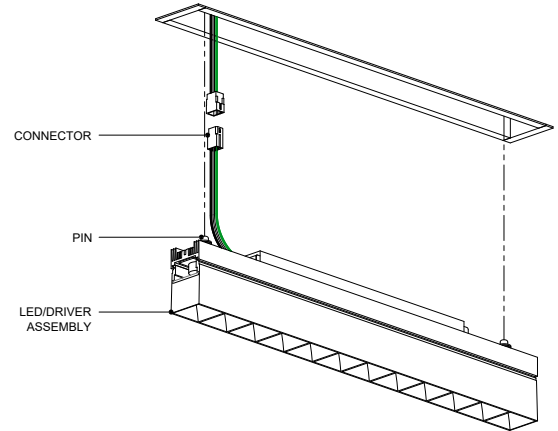

Step E

For run lengths that require multiple sections. Lift housing into place until flush and aligned. Guide pin/joiner into corresponding slot. Mount fixture to surface as shown in step D.

