

Installation Instructions

Core 4" Round - Flangeless Trim - Panel Mount

for CR4D-RA, CR4D-RF, CR4WW-RA, CR4WW-RF, CR4MD-RDH, CR4VD-RA

Cautions and Warnings

1. This product must be installed in accordance with the applicable installation code by a licensed electrician familiar with the construction and operation of the product and hazards involved.
2. Power must be OFF when connecting the fixture. "hot plugging" the light engine and driver will damage the LED source.
3. The light engine is low voltage and is factory wired to the driver DO NOT CONNECT LIGHT ENGINE TO MAINS AC POWER.
4. LEDs should be protected from dust and debris during installation and maintenance.
5. Polarity is important. Black must be connected to black and red connected to red.
6. Not designed for use as temporary lighting.

Step B

Make electrical connections in junction box.

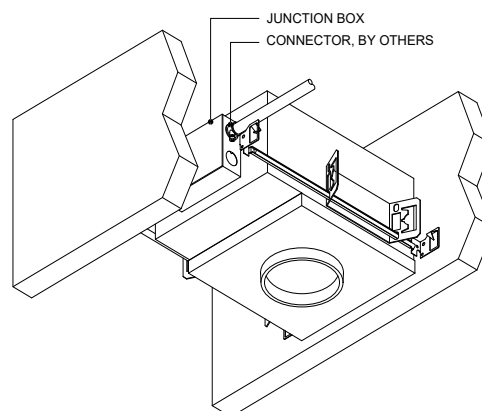

Step A

Mount housing to structure using included hanger bars. Adjust butterfly bracket position using internal wing nut to bottom of slot, so that housing is in the highest position with respect to butterfly bracket. In this position there is 1/2" of vertical adjustment to lower housing to meet counterbore of base ceiling. Mount fixture to structure so that the throat is coplanar topside of finished ceiling/bottom of framing members.

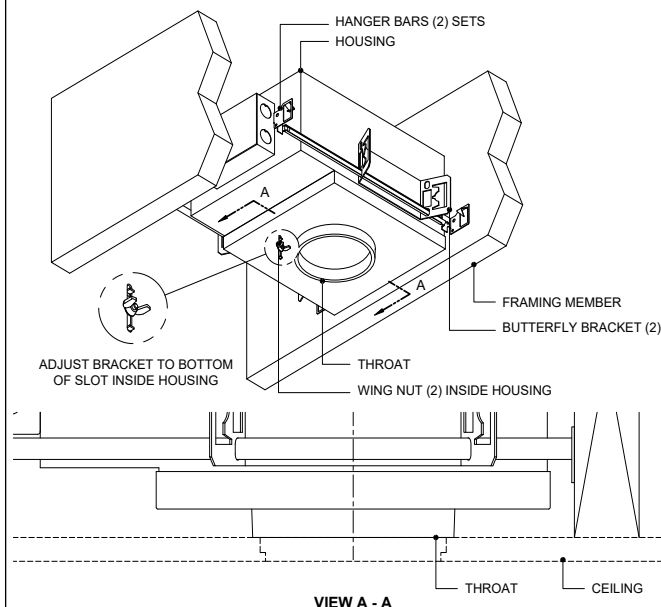

Step C

Install panel collar into throat by threading collar clockwise into throat. Adjust into housing until face of collar is approximately 1/8" above elevation of finished ceiling.

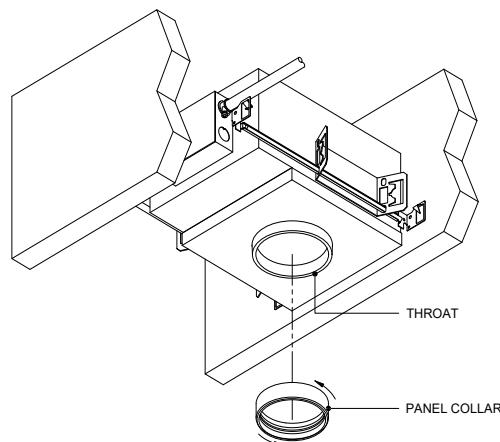

**** LED'S SHOULD BE PROTECTED FROM DUST AND DEBRIS DURING INSTALLATION AND MAINTENANCE**

[Click here to read full Care and Maintenance](#)

Installation Instructions Core 4" Round - Flangeless Trim - Panel Mount

for CR4D-RA, CR4D-RF, CR4WW-RA, CR4WW-RF, CR4MD-RDH, CR4VD-RA

Step D

1. Cut $\text{Ø}4 - 1/16"$ hole in panel.
2. Counterbore $\text{Ø}4 - 5/16"$ backside on base ceiling panel.

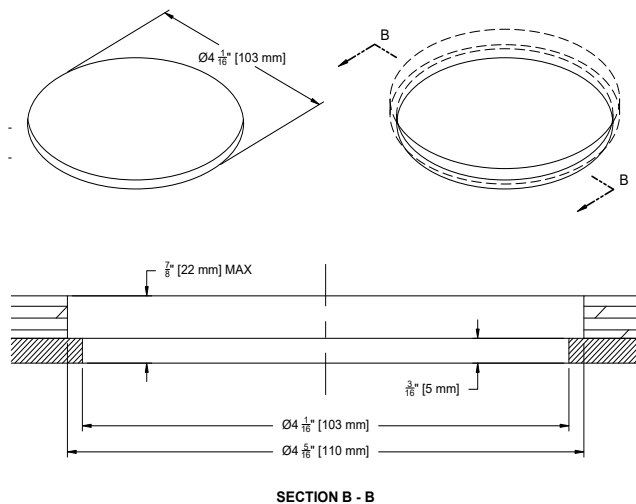

Step F

Push trim into collar until ball plungers engage the retainer within the collar. Panel opening should not be larger than $\text{Ø}4 - 1/16"$ [103 mm].

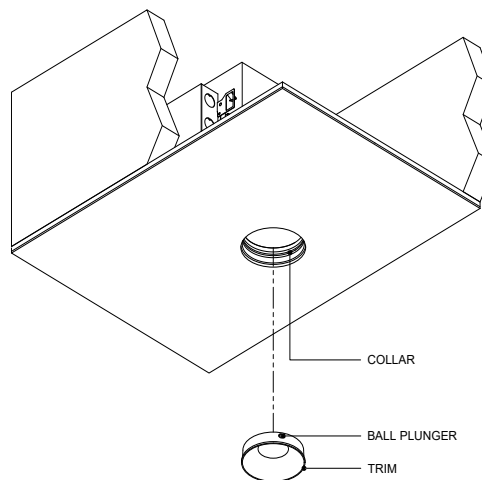

Step E

Install ceiling ensuring counterbore and cut-out align with housing throat and panel collar. Lower housing by loosening internal wing nut on butterfly bracket and moving housing down until face of throat meets topside of ceiling. Turn panel collar counter-clockwise until face of panel collar meets the topside of the panel, within counterbore.

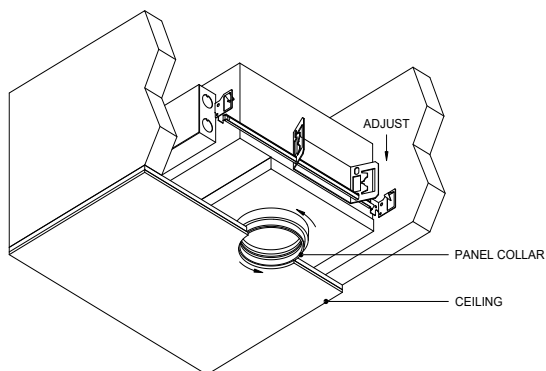

Step G

Ensure trim is properly secured with the ball plungers. If trim is not flush with finished ceiling, remove trim by pulling downward on trim until ball plungers disengage from collar. Thread collar clockwise or counter-clockwise to adjust height of collar. Re-install trim.

