

Installation Instructions

Core 4" Round Flanged Trim - Universal Housing

for CR4D-RA, CR4D-RF, CR4WW-RA, CR4WW-RF, CRV4D-RA, and CR4MD-RDML

Cautions and Warnings

1. This product must be installed in accordance with the applicable installation code by a licensed electrician familiar with the construction and operation of the product and hazards involved.
2. Power must be OFF when connecting the fixture. "hot plugging" the light engine and driver will damage the LED source.
3. The light engine is low voltage and is factory wired to the driver DO NOT CONNECT LIGHT ENGINE TO MAINS AC POWER.
4. LEDs should be protected from dust and debris during installation and maintenance.
5. Polarity is important. Black must be connected to black and red connected to red.
6. Not designed for use as temporary lighting.

Step B

Make electrical connections in junction box.

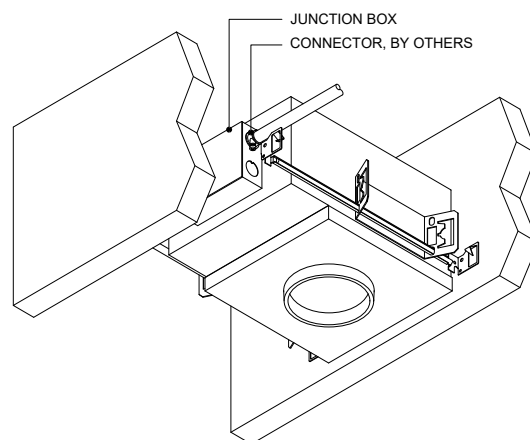

Step A

Mount housing to structure using included hanger bars. Adjust butterfly bracket position using internal wing nut to bottom of slot, so that housing is in the highest position with respect to butterfly bracket. Mount housing so that face of throat is 1/4" above top side of ceiling/bottom of framing members.

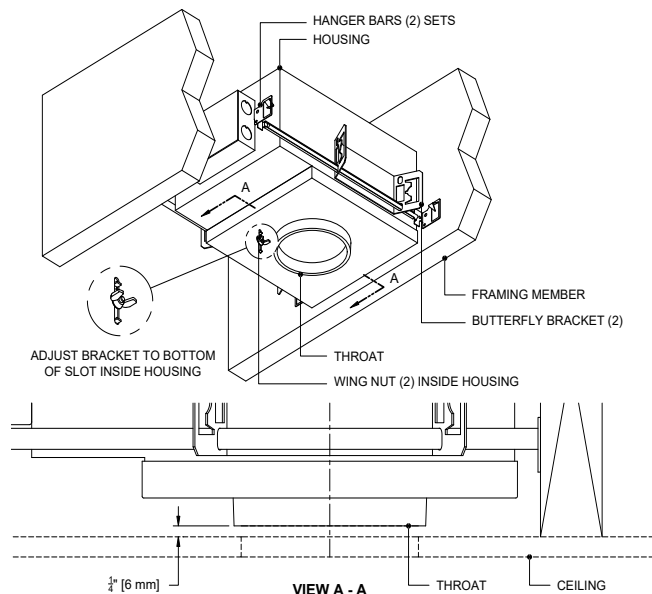

Step C

Cut $\text{Ø}4 - 5/16"$ [110 mm] cut-out in ceiling.

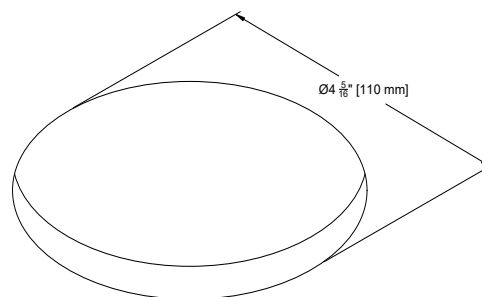

** LED'S SHOULD BE PROTECTED FROM DUST AND DEBRIS DURING INSTALLATION AND MAINTENANCE

[Click here to read full Care and Maintenance](#)

Installation Instructions

Core 4" Round Flanged Trim - Universal Housing

for CR4D-RA, CR4D-RF, CR4WW-RA, CR4WW-RF, CRV4D-RA, and CR4MD-RDML

Step D

Install ceiling ensuring the center of the cut-out aligns with center of housing throat. Lower housing by loosening internal wing nut on butterfly bracket and moving housing down until face of throat meets topside of ceiling.

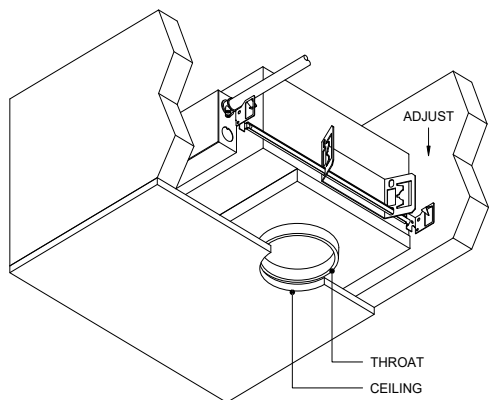

Step F

Push trim into collar until ball plungers engage the retainer within the collar.

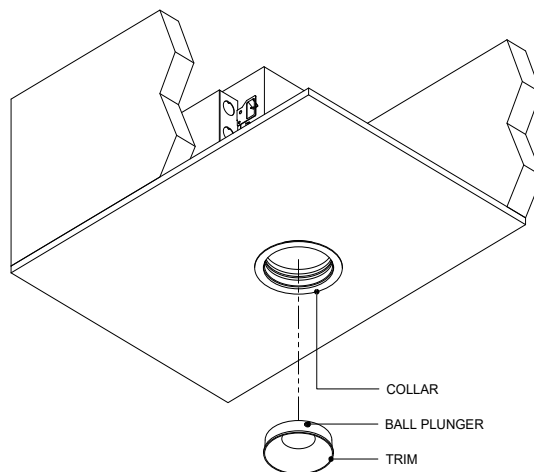

Step E

Install flanged collar by threading collar clockwise into throat until flange is flush against ceiling.

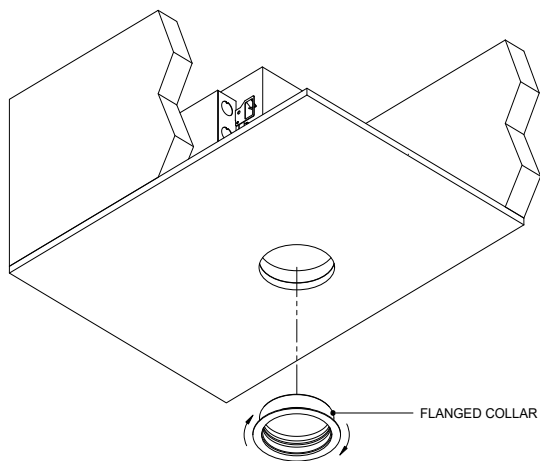

Step G

Ensure trim is properly secured with the ball plungers. If flange is not flush with finished ceiling, remove trim by pulling downward on trim until ball plungers disengage from collar. Thread collar clockwise until it is flush with the ceiling. Reinstall trim.

