

Installation Instructions Mural 5" Linear - Continuous Wall Wash

for MU5-RM-PM

Cautions and Warnings

1. This product must be installed in accordance with the applicable installation code by a licensed electrician familiar with the construction and operation of the product and hazards involved.
2. Power must be OFF when connecting the fixture. "hot plugging" the light engine and driver will damage the LED source.
3. The light engine is low voltage and is factory wired to the driver DO NOT CONNECT LIGHT ENGINE TO MAINS AC POWER.
4. LEDs should be protected from dust and debris during installation and maintenance.
5. Polarity is important. Black must be connected to black and red connected to red.
6. Not designed for use as temporary lighting.

Step B

Prior to installing the housing in ceiling. Connect power to fixture through wiring access plate by removing two screws that fasten the plate to the housing. Replace wiring access plate.

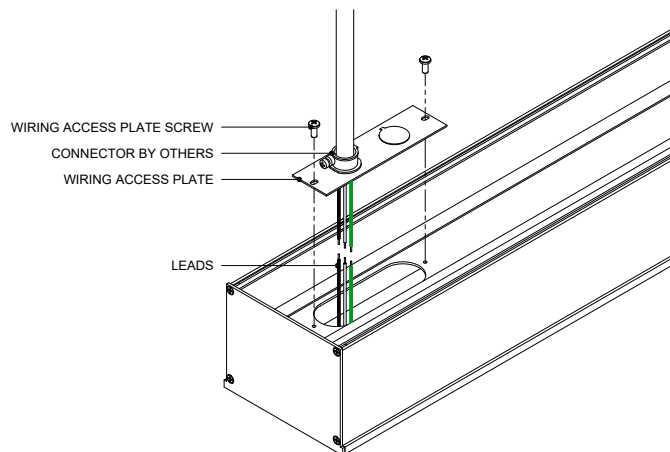

Step A

Install blocking tied to framing at the height above finished floor as indicated on submittal drawing, in locations as indicated on submittal drawings. Make cutout in ceiling at dimensions indicated on submittal drawing.

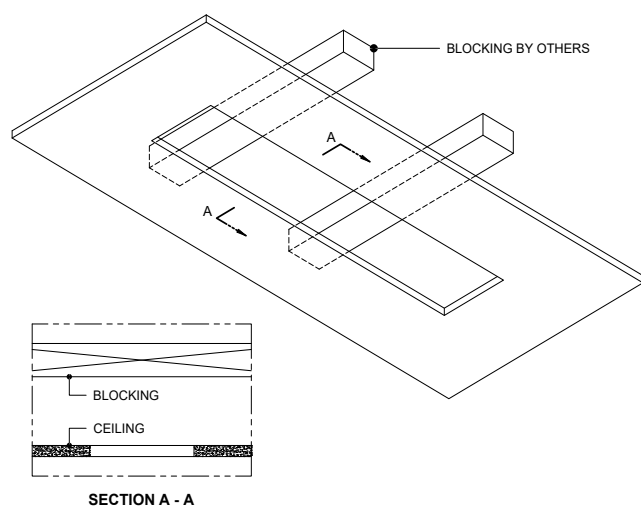

Step C

Mount fixture through housing to blocking above cutout with #8 wood screws or fasteners suitable for blocking material used.

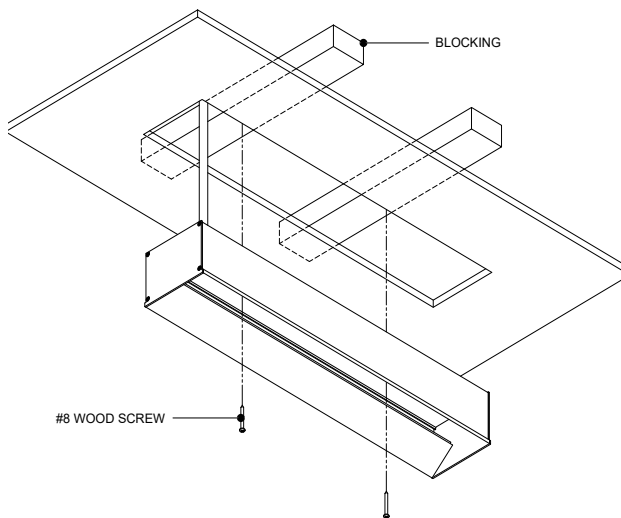

**** LED'S SHOULD BE PROTECTED FROM DUST AND DEBRIS DURING INSTALLATION AND MAINTENANCE**

[Click here to read full Care and Maintenance](#)

Installation Instructions Mural 5" Linear - Continuous Wall Wash

for MU5-RM-PM

Step D

For run lengths that require multiple sections. Lift housing into place until flush and aligned. Guide pin/joiner into corresponding slot. Mount fixture in ceiling as shown in step C.

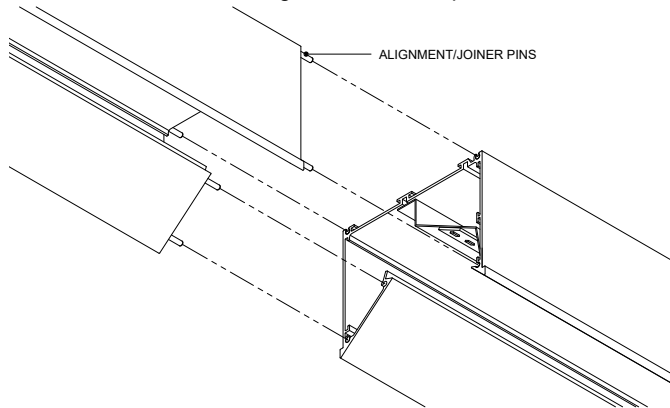

Step E

Install lens into aperture. Test with power.

