



SCOM-RA Monopoint (SCOM-RA-) Installation Instructions

Integral Driver with 4" deep handy box - Pages 1 - 3

- SCOM-RA-F-SM – Flanged Surface Mount for GWB or Wood Ceiling [1](#)
- SCOM-RA-Z-SM – Flangeless (Plaster) Surface Mount for GWB Ceiling [2](#)
- SCOM-RA-Z-PM – Flangeless Panel Mount for Wood Ceiling [3](#)

Remote Driver with 2" deep handy box - Pages 4 - 6

- SCOM-RA-F-SMR – Flanged Surface Mount for GWB or Wood Ceiling [4](#)
- SCOM-RA-Z-SMR – Flangeless (Plaster) Surface Mount for GWB Ceiling [5](#)
- SCOM-RA-Z-PMR – Flangeless Surface Mount for Wood Ceiling [6](#)

Remote Driver – Retrofit or new construction - Shallow Mounting - Pages 7 - 9

- SCOM-RA-F-SHM – Flanged Shallow Surface Mount for GWB or wood Ceiling.. [7](#)
- SCOM-RA-Z-SMH - Flangeless Shallow Surface Mount for GWB Ceiling [8](#)
- SCOM-RA-Z-SHPM – Flangeless Shallow Panel Mount for Wood Ceiling [9](#)

Remote Driver with Pancake or Octagonal Box - Canopy Mounting - Pages 10

- SCOM-RA-CP-CM – Canopy Mount for GWB or wood ceiling [10](#)

SCOM-RA Monopoint (SCOM-RA-F-SM)

Flanged Surface Mount Install with Integral Driver (GWB or Wood Ceiling)

INCLUDED



Flanged Receiver

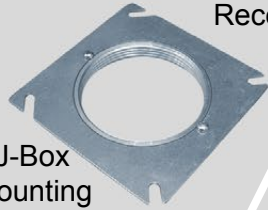

J-Box Mounting hardware*

*J-Box Mounting hardware is reversible. Refer to Step 2 for mounting orientation.

NOT INCLUDED



Hanger Bar for RACO J-BOXES
Supplied by others
RACO- HUBBELL CAT#920

J-Boxes Recommend
Supplied by others

RACO PN#255 w/Bracket
or RACO PN#256 w/o Bracket

OPTIONAL:
RACO PN#201
1-1/2" Extension Box
(for additional wiring space)

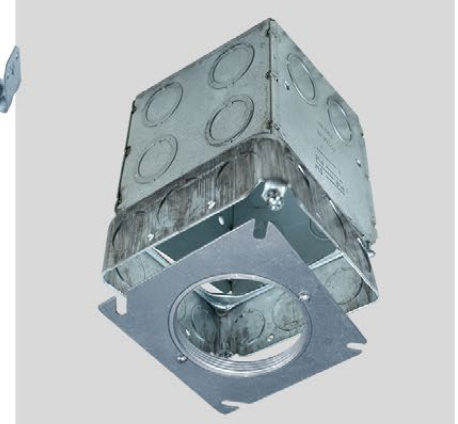

Step 2- Attach J-Box Mounting Hardware with threaded ring inserted (ring up) into J-BOX using two screws.

Step 1- J-Boxes, hanger bars and/or mounting brackets are not included. Please purchase.

Option 1: Hanger bar for spanning ceiling joists



Option 2- Align J-Box assembly with bottom of joist. Nail to joist.



Paint ceiling prior to installing Flange Trim.

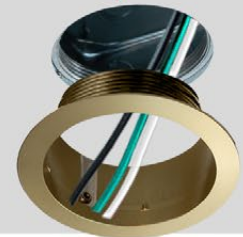

Step 3- Align j-box assembly with bottom of joist and attach to joists with hanger bars.

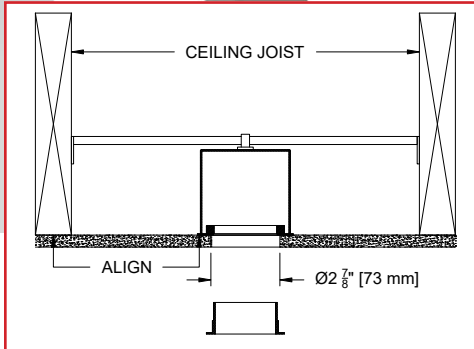

Step 5- Pull power supply and control wires (if required) through ceiling aperture and through the flanged receiver before threading receiver into J-box mounting hardware. Thread until flange receiver is tight to ceiling.

Step 4- Attach ceiling to structure with cutouts as shown. Finish and paint ceiling.

Supplied Quick Connection

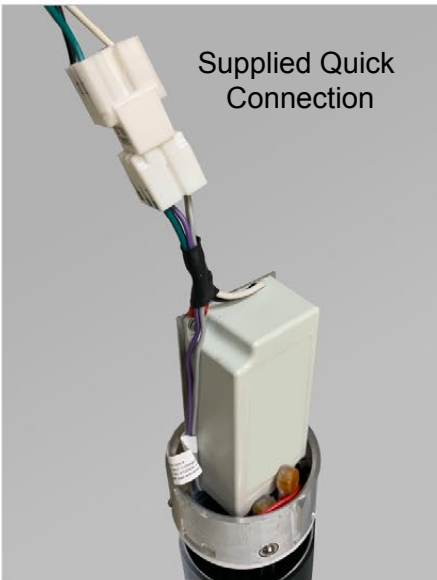

Step 6- Before starting step 7, make sure all electrical connections are working

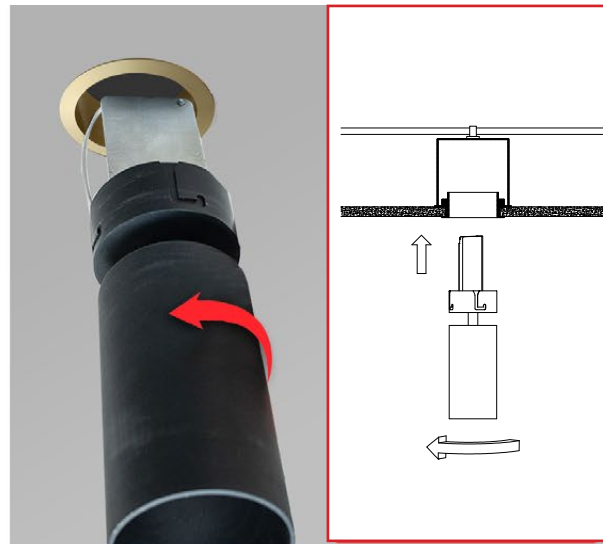

Step 7- Align fixture j-hook slots with cleats in flanged receiver. Push up and rotate counter-clockwise until rotation stops and fixture drops to flush position. Canopy should be flush with flange/ceiling.

Note: This product must be installed in accordance with the applicable installation code by a person familiar with the construction and operation of the product hazards involved. It is recommended these products be installed by a qualified electrician.

SCOM-RA Monopoint (SCOM-RA-Z-SM)

Flangeless Plaster Install with Integral Driver (GWB/Plaster Ceiling)

INCLUDED



J-Box Mounting hardware*

*J-Box Mounting hardware is reversible. Refer to Step 2 for mounting orientation.



Flangeless Plaster Receiver

NOT INCLUDED

Hanger Bar for RACO J-BOXES
Supplied by others
RACO- HUBBELL CAT#920

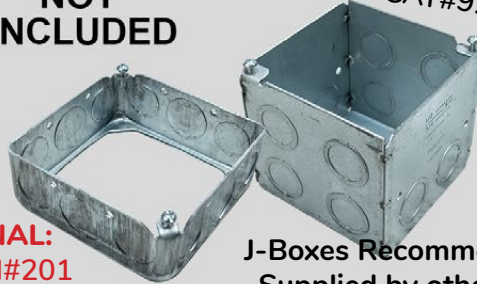

J-Boxes Recommend
Supplied by others
RACO PN#255 w/Bracket
or RACO PN#256 w/o Bracket

OPTIONAL:
RACO PN#201
1-1/2" Extension Box
(for additional wiring space)

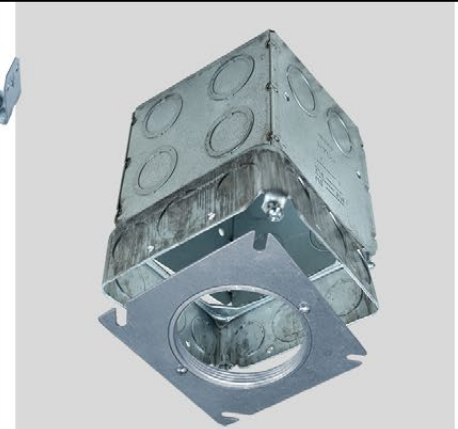

Step 2- Attach J-Box Mounting Hardware with threaded ring inserted (ring up) into J-BOX using two screws.

Step 1- J-Boxes, hanger bars and/or mounting brackets are not included. Please purchase.

Option 1: Hanger bar for spanning ceiling joists

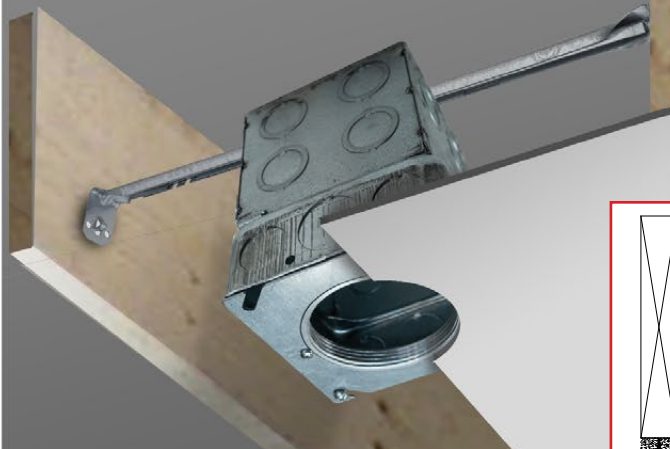

Option 2- Align J-Box assembly with bottom of joist. Nail to joist.



Step 3- Align j-box assembly with bottom of joist and attach to joists with hanger bars.

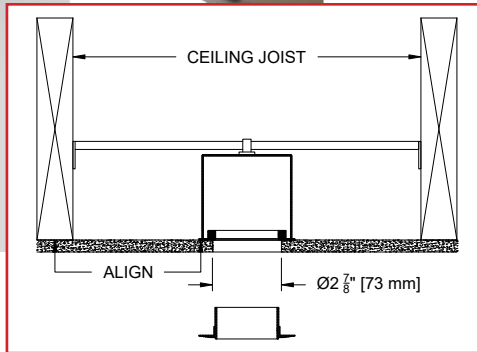

Step 4- Attach ceiling to structure with cutouts as shown. Finish and paint ceiling.

Plaster over flange.
Allow to dry then paint



Step 5- Pull power supply and control wires (if required) through ceiling aperture and through the flangeless plaster receiver before threading receiver into J-box mounting hardware. Thread until plaster flange receiver is tight to ceiling. Plaster over mud ring flange, then finish and paint.

Supplied Quick Connection



Step 6- Before starting step 7, make sure all electrical connections are working

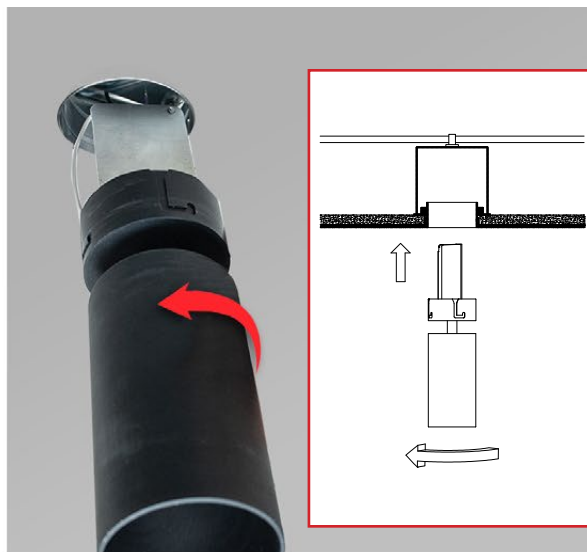

Step 7- Align fixture j-hook slots with cleats in flangeless plaster receiver. Push up and rotate counter-clockwise until rotation stops and fixture drops to flush position. Canopy should be flush with ceiling. Install complete.

Note: This product must be installed in accordance with the applicable installation code by a person familiar with the construction and operation of the product hazards involved. It is recommended these products be installed by a qualified electrician.

SCOM-RA Monopoint (SCOM-RA-Z-PM)

Flangeless Millwork Install with Integral Driver (Wood/Millwork Ceiling)

INCLUDED

J-Box Mounting hardware*

*J-Box Mounting hardware is reversible when installing. Refer to Step 2 for mounting orientation.

Panel Mount Receiver

NOT INCLUDED

Hanger Bar for RACO J-BOXES
Supplied by others
RACO- HUBBELL CAT#920

OPTIONAL:
RACO PN#201

1-1/2" Extension Box (for additional wiring space) or RACO PN#256 w/o Bracket

J-Boxes Recommend
Supplied by others
RACO PN#255 w/Bracket

Step 2- Attach J-Box Mounting Hardware with threaded ring extended (ring down) from J-BOX using two screws.

Step 1- J-Boxes, hanger bars and/or mounting brackets are not included. Please purchase.

Option 1: Hanger bar for spanning ceiling joists

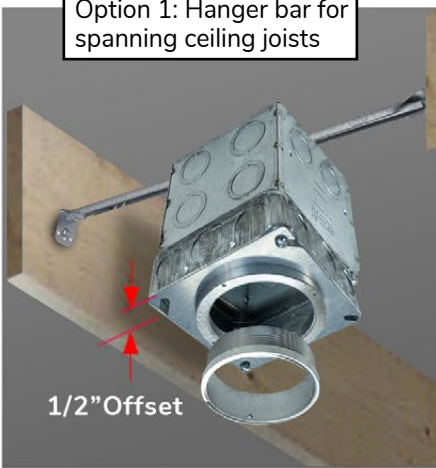

1/2" Offset

Option 2- Attach j-box assembly 1/2" above bottom of joist. Nail to joist.



1/2" Offset measured between mounting hardware plate and bottom of joist

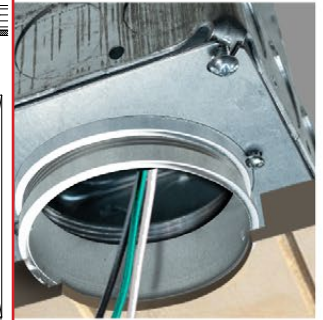
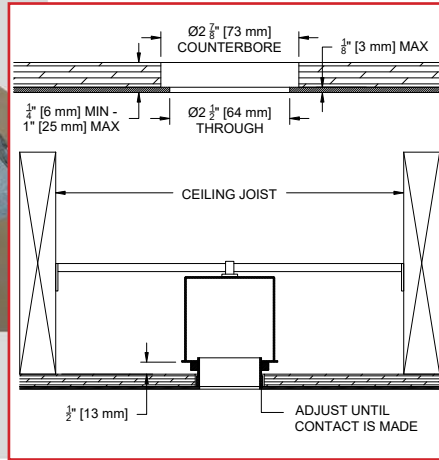

Step 3- Using hanger bars, attach j-box assembly so that J-box mounting hardware plate is 1/2" above bottom of joists.

Step 3a- Thread panel mount receiver fully into J-Box Mounting hardware.

Step 4 - Cut and counter-bore millwork (see drawings above) before installing ceiling. Verify that cutouts align with panel mount receiver.

Step 5 - Attach ceiling to structure with cutouts as shown.

Step 5a-Back out panel mount receiver until it stops against millwork counter-bore.

Step 5b-Pull power supply and control wires (if required) through ceiling aperture.

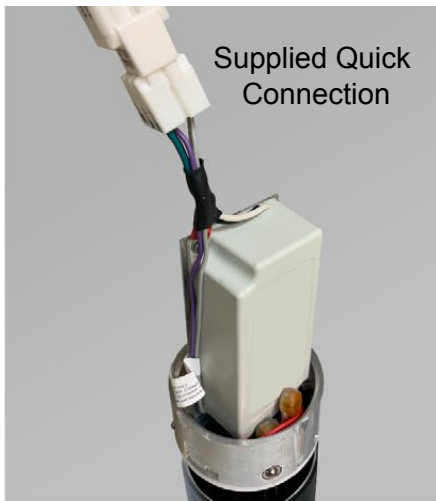

Step 6- Make sure all electrical connections are working before installing Monopoint into ceiling

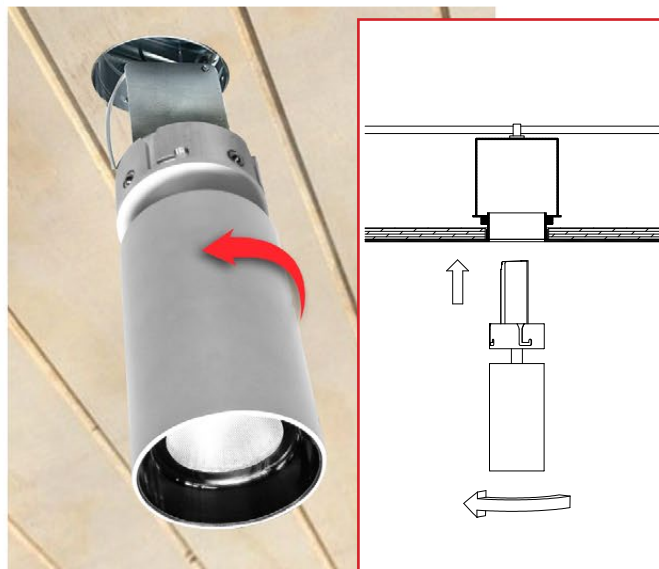

Step 7- Align fixture j-hook slots with cleats in receiver. Push up and rotate counter-clockwise until rotation stops and fixture drops to flush position. Canopy should be flush with ceiling. Install complete

Note: This product must be installed in accordance with the applicable installation code by a person familiar with the construction and operation of the product hazards involved. It is recommended these products be installed by a qualified electrician.

SCOM-RA Monopoint (SCOM-RA-F-SMR)

Flanged Surface Mount Install with Remote Driver (GWB or Wood Ceiling)

INCLUDED



Flanged Receiver

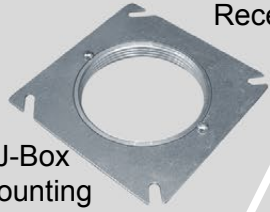

J-Box Mounting hardware*

*J-Box Mounting hardware is reversible. Refer to Step 2 for mounting orientation.

NOT INCLUDED

Hanger Bar for RACO J-BOXES
Supplied by others
RACO- HUBBELL CAT#920

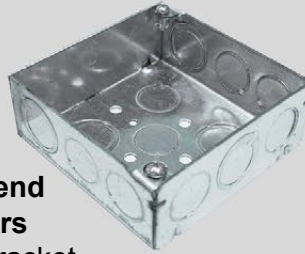

J-Boxes Recommend
Supplied by others
RACO PN#232 w/o Bracket

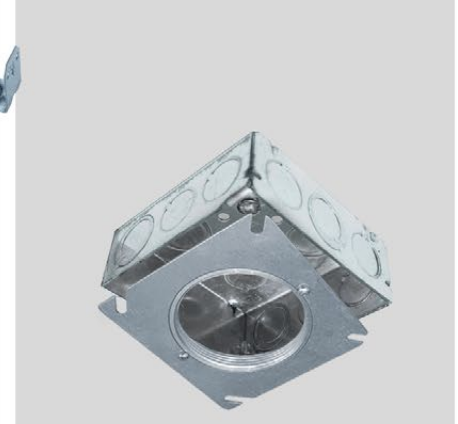

Step 2- Attach J-Box Mounting Hardware with threaded ring inserted (ring up) into J-BOX using two screws.

Step 1- J-Boxes, hanger bars and/or mounting brackets are not included. Please purchase.

Option 1: Hanger bar for spanning ceiling joists



Option 2- Align J-Box assembly with bottom of joist. Nail to joist.

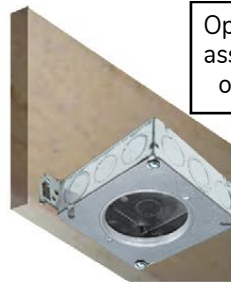

Step 3- Align j-box assembly with bottom of joist and attach to joists with hanger bars.

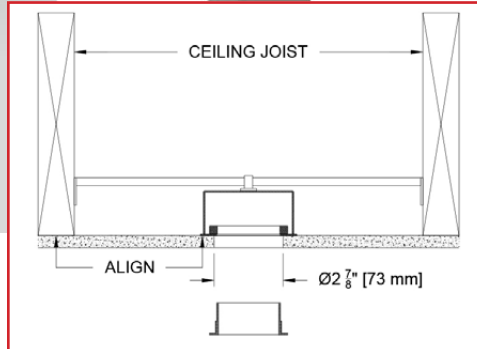

Step 4- Attach ceiling to structure with cutouts as shown. Finish and paint ceiling.

Paint ceiling prior to installing Flange Trim.



Step 5- Pull power supply and control wires (if required) through ceiling aperture and through the flanged receiver before threading receiver into J-box mounting hardware.

Step 5a-Thread until flange receiver is tight to ceiling.

Supplied Quick Connection



Step 6- Before starting step 7, make sure all electrical connections are working

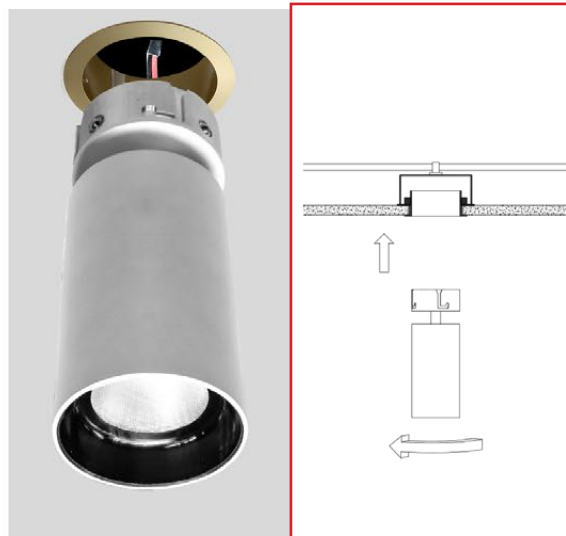

Step 7- Align fixture j-hook slots with cleats in flanged receiver. Push up and rotate counter-clockwise until rotation stops and fixture drops to flush position. Canopy should be flush with flange/ceiling.

Note: This product must be installed in accordance with the applicable installation code by a person familiar with the construction and operation of the product hazards involved. It is recommended these products be installed by a qualified electrician.

SCOM-RA Monopoint (SCOM-RA-Z-SMR)

Flangeless Plaster Install with Remote Driver (GWB/Plaster Ceiling)

INCLUDED

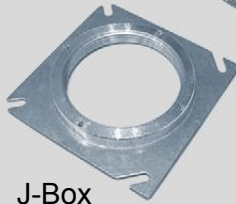

J-Box Mounting hardware*

*J-Box Mounting hardware is reversible. Refer to Step 2 for mounting orientation.



Flangeless Plaster Receiver

NOT INCLUDED

Hanger Bar for RACO J-BOXES
Supplied by others
RACO- HUBBELL CAT#920

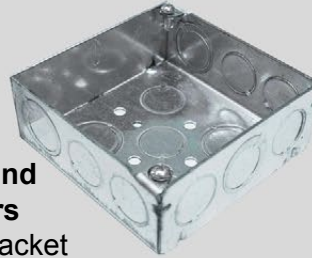

J-Boxes Recommend
Supplied by others
RACO PN#232 w/o Bracket

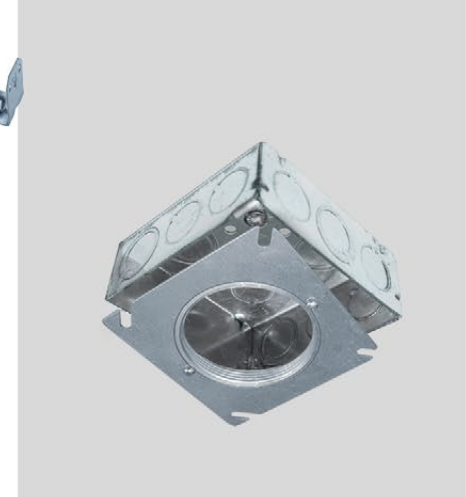

Step 2- Attach J-Box Mounting Hardware with threaded ring inserted (ring up) into J-BOX using two screws.

Step 1- J-Boxes, hanger bars and/or mounting brackets are not included. Please purchase.



Step 3- Align j-box assembly with bottom of joist and attach to joists with hanger bars.

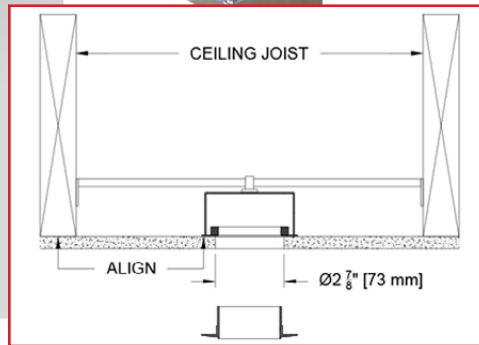

Step 4- Attach ceiling to structure with cutouts as shown. Finish and paint ceiling.

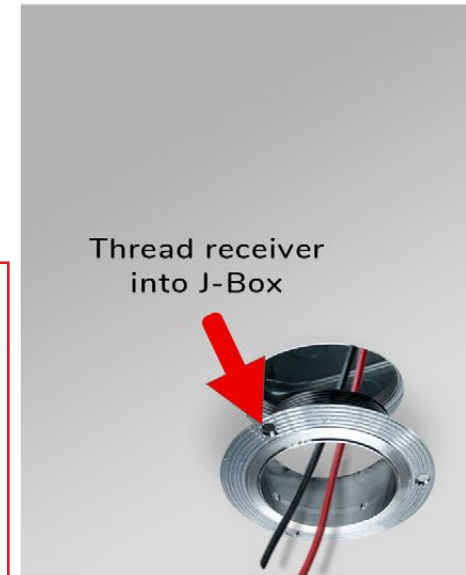

Thread receiver into J-Box

Step 5- Pull wires from remote driver through ceiling cutout and through the flangeless plaster receiver before installing receiver into ceiling.

Step 5a- Thread flangeless plaster receiver into J-Box till tight to ceiling.

Plaster over flange. Allow to dry then paint



Step 6- Plaster and paint mud ring. Make electrical connections, red to red (+) and black to black (-). Test electrical connections prior to installing luminaire.

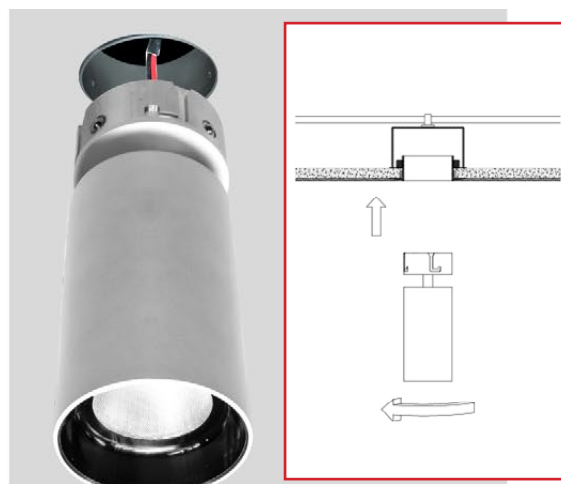

Step 7- Align fixture j-hook slots with cleats in collar. Push up and rotate counter-clockwise until rotation stops and fixture canopy drops flush with ceiling and ball plungers are engaged. Installation complete.

Note: This product must be installed in accordance with the applicable installation code by a person familiar with the construction and operation of the product hazards involved. It is recommended these products be installed by a qualified electrician.

SCOM-RA Monopoint (SCOM-RA-Z-PMR) Formerly SCOM-RA-Z-SHPM

Flangeless Millwork Install with Remote Driver (Wood/Millwork Ceiling)

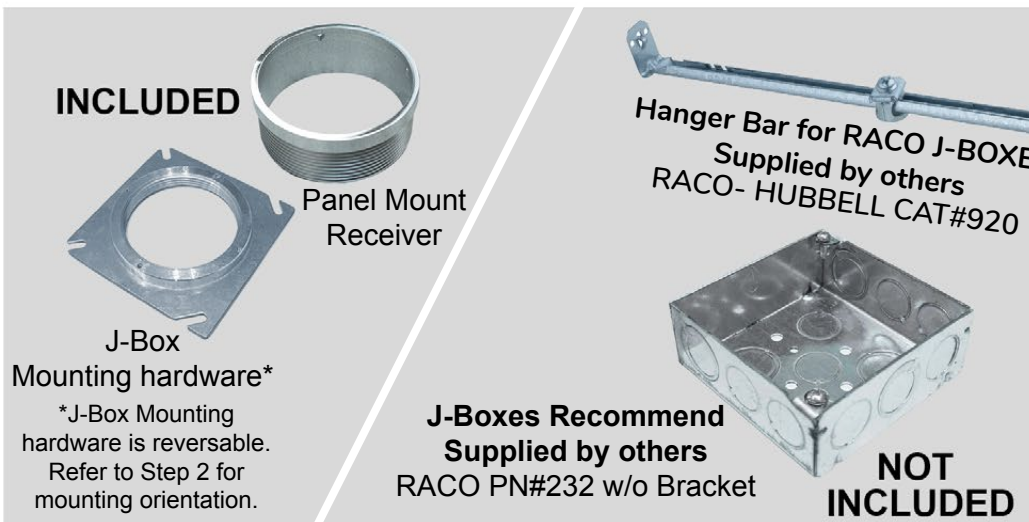

Step 2- Attach J-Box Mounting Hardware with threaded ring extended (ring down) from J-BOX using two screws.

Step 1- J-Boxes, hanger bars and/or mounting brackets are not included. Please purchase.

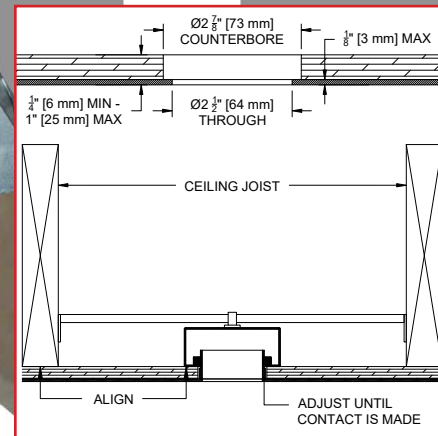
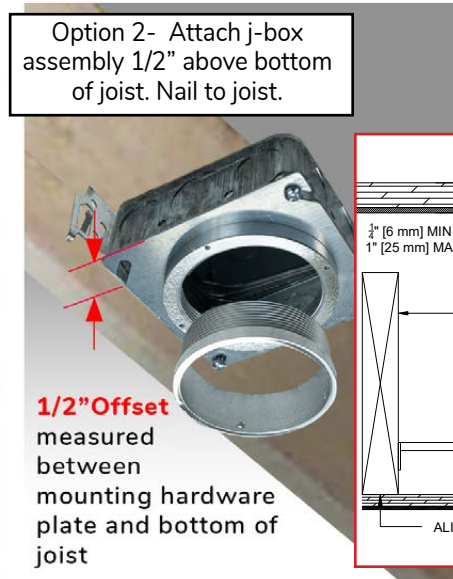
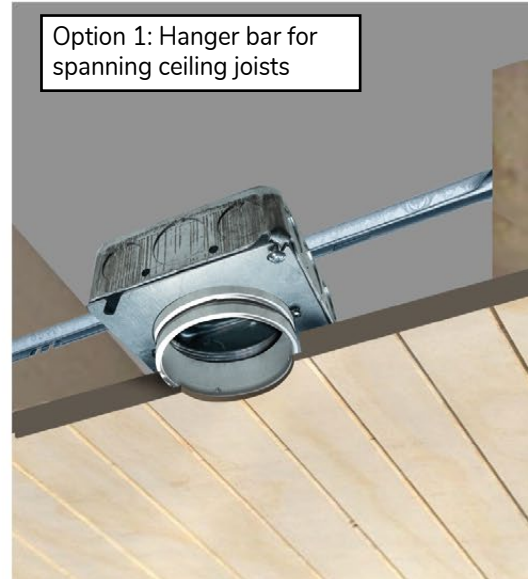

Step 3- Using hanger bars, attach j-box assembly so that J-box mounting hardware plate is 1/2" above bottom of joists. Step 3a- Thread panel mount receiver fully into J-Box Mounting hardware.

Step 4 - Cut and counter-bore millwork (see drawings above) before installing ceiling. Verify that cutouts align with panel mount receiver

Step 5- Attach ceiling to structure with cutouts as shown.

Step 5a- Back out panel mount receiver until it stops against millwork counter-bore.

Step 5b- Pull LED fixture wires through ceiling aperture and make electrical connections, red to red (+) and black to black (-).

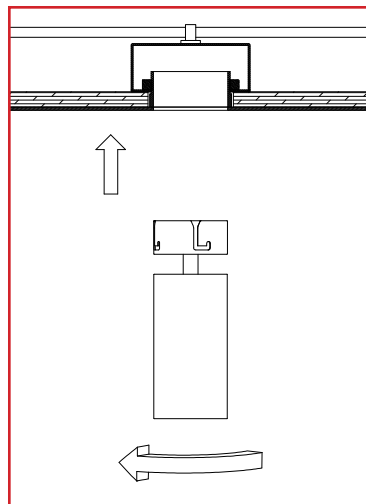

Step 6 and 7- Make sure all electrical components are working prior to inserting fixture in receiver. Align fixture j-hook slots with cleats in receiver. Push up and rotate counter-clockwise until rotation stops and fixture drops to flush position. Canopy should be flush with ceiling. Install complete.

Note: This product must be installed in accordance with the applicable installation code by a person familiar with the construction and operation of the product hazards involved. It is recommended these products be installed by a qualified electrician.

SCOM-RA Monopoint (SCOM-RA-F-SHM)

Flanged Surface Mount Install with Remote Driver (GWB Ceiling)

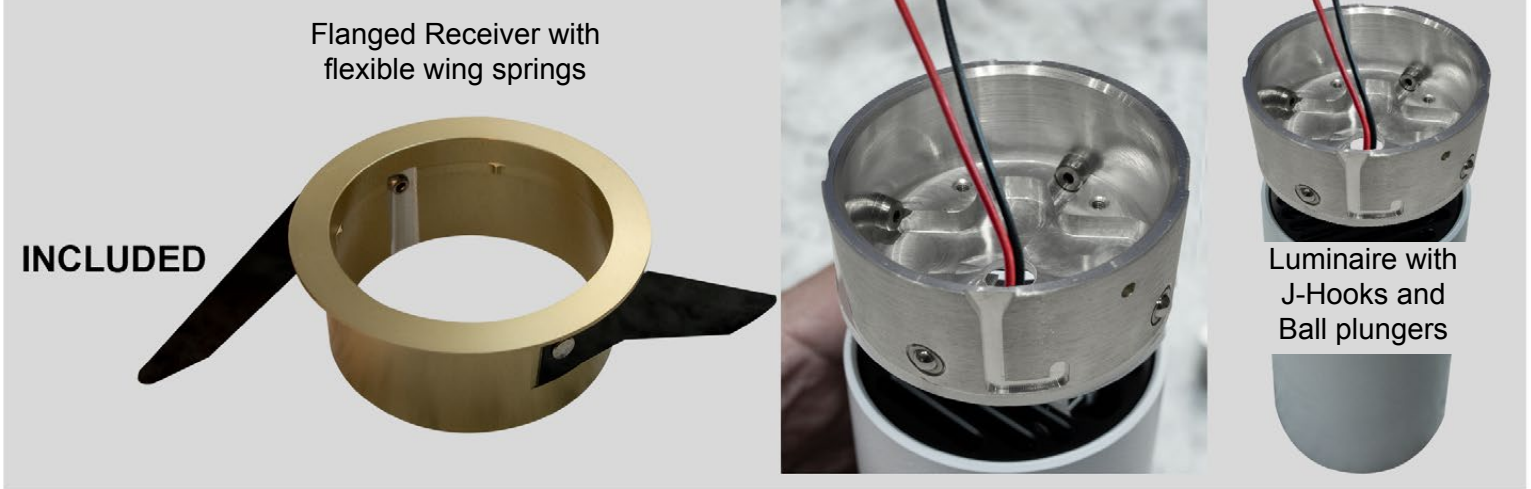

Step 1- Verify that all parts shown are included in packaging (Collar and Luminaire)

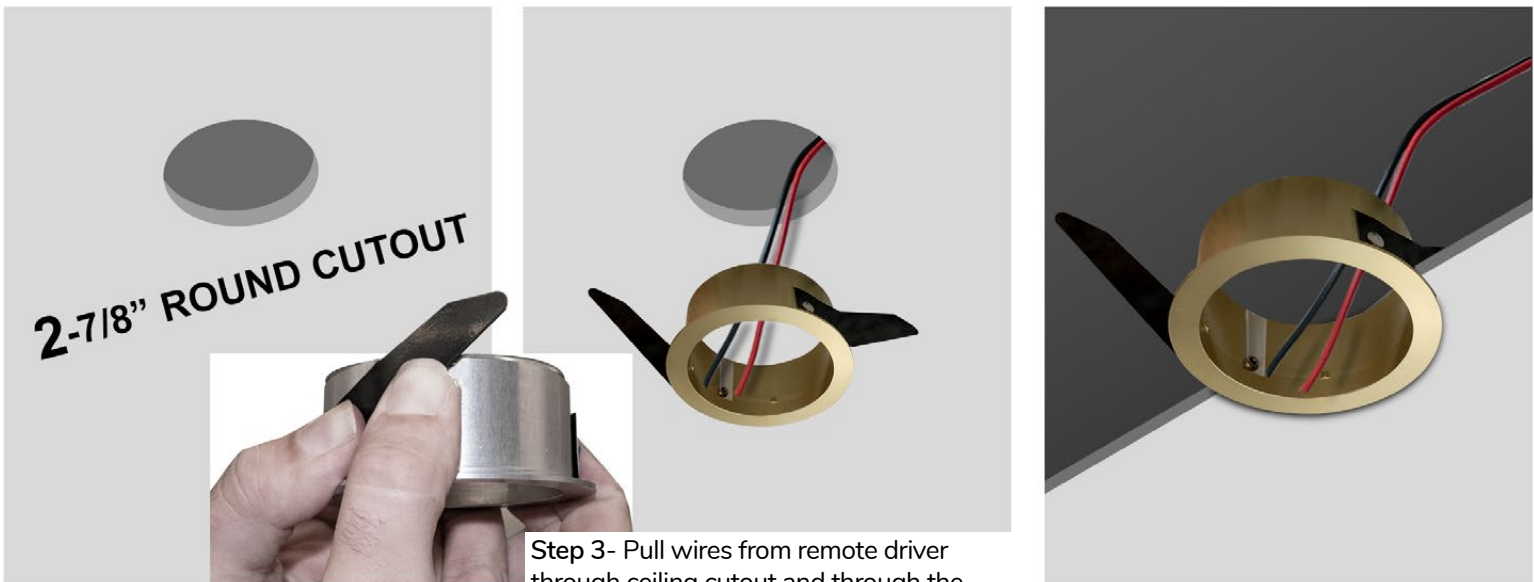

Step 2- Cut 2-7/8" diameter hole in GWB. Prep/finish and paint ceiling before installing Flanged Receiver with wing springs.

Step 4- Flange should be tight against ceiling and wing springs should securely engage GWB.

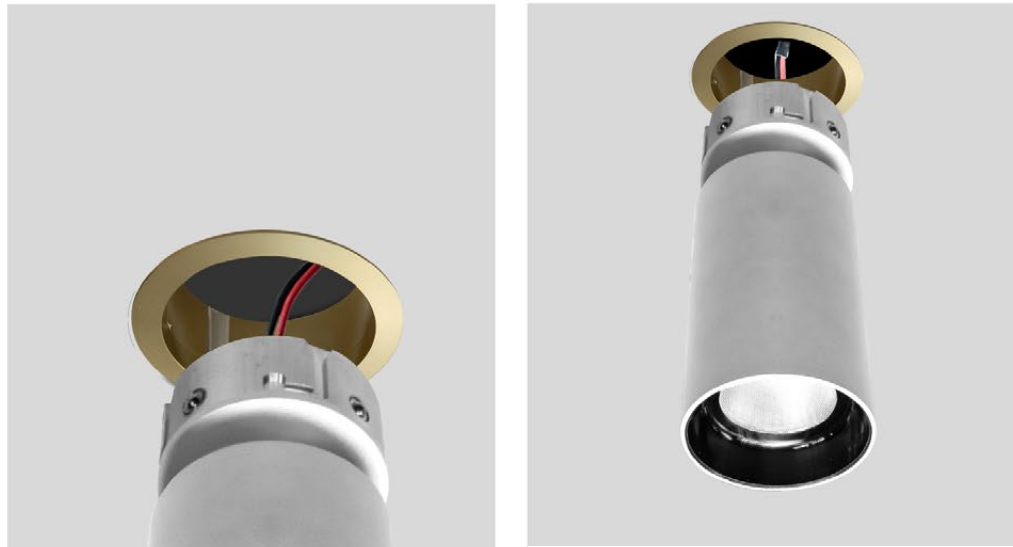

Note: This product must be installed in accordance with the applicable installation code by a person familiar with the construction and operation of the product hazards involved. It is recommended these products be installed by a qualified electrician.

Step 5- Make electrical connections, red to red (+) and black to black (-). Test electrical connections prior to installing luminaire

Step 6- Align fixture j-hook slots with cleats in collar. Push up and rotate counter-clockwise until rotation stops and fixture canopy drops flush with ceiling and ball plungers are engaged. Installation complete.

SCOM-RA Monopoint (SCOM-RA-Z-SHM)

Flangeless Surface Mount Install with Remote Driver (GWB Ceiling)

Flangeless Plaster Receiver with adjustable wing clamps

INCLUDED



Luminaire with J-Hooks and Ball plungers

Step 1- Verify that all parts shown are included in packaging (Collar and Luminaire).

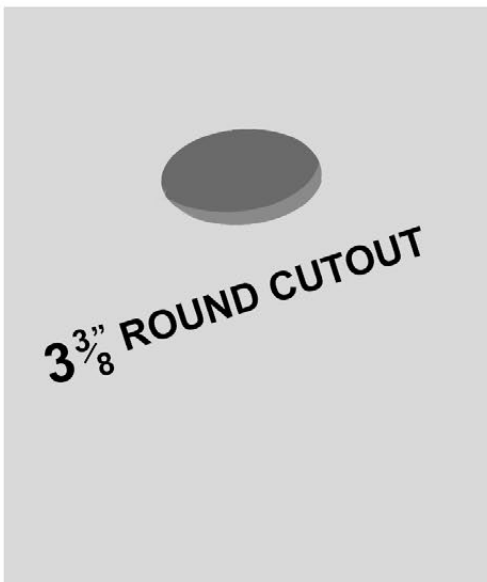

3 3/8" ROUND CUTOUT

Step 2- Cut 3" diameter hole with tabs as indicated above in GWB ceiling.

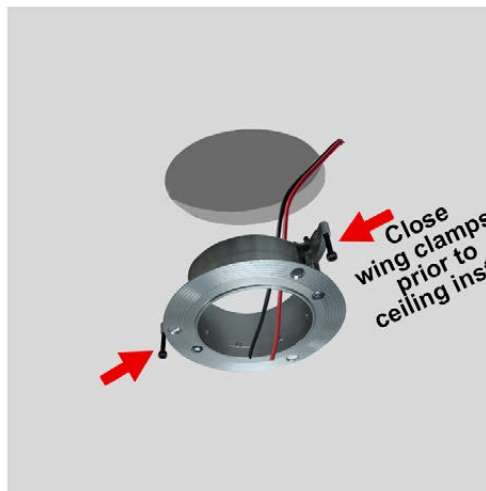

Step 3- Pull wires from remote driver through ceiling cutout and through the flangeless plaster receiver before installing receiver into ceiling. Align wing clamps with tab cutouts to fit plaster receiver and fit receiver into opening.



Step 4- Tighten two screws in mud-ring to rotate wing clamps into position to tightly secure flangeless plaster receiver against ceiling.



Step 5- Plaster and paint mud ring. Make electrical connections, red to red (+) and black to black (-). Test electrical connections prior to installing luminaire.



Step 6- Align fixture j-hook slots with cleats in collar. Push up and rotate counter-clockwise until rotation stops and fixture canopy drops flush with ceiling and ball plungers are engaged. Installation complete.

Note: This product must be installed in accordance with the applicable installation code by a person familiar with the construction and operation of the product hazards involved. It is recommended these products be installed by a qualified electrician.

SCOM-RA Monopoint (SCOM-RA-Z-SHPM)

Flangeless Millwork Install with Remote Driver (Wood/Millwork Ceiling)

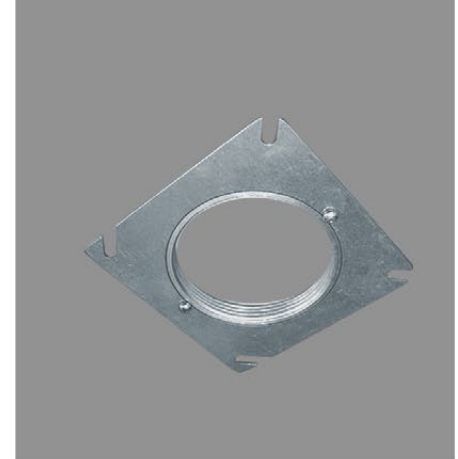
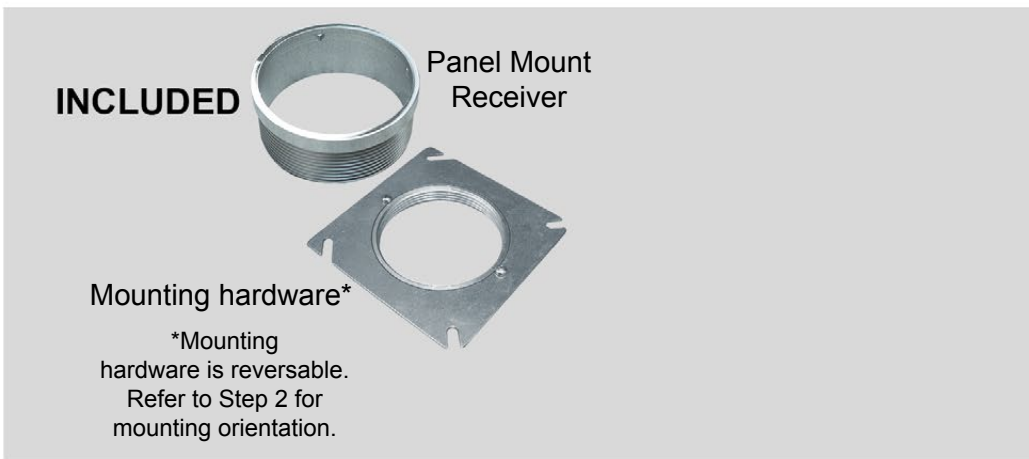

Step 1- Panel Mount Receiver comes standard with Mounting hardware.

Step 2- threaded ring needs to face upward on mounting hardware.

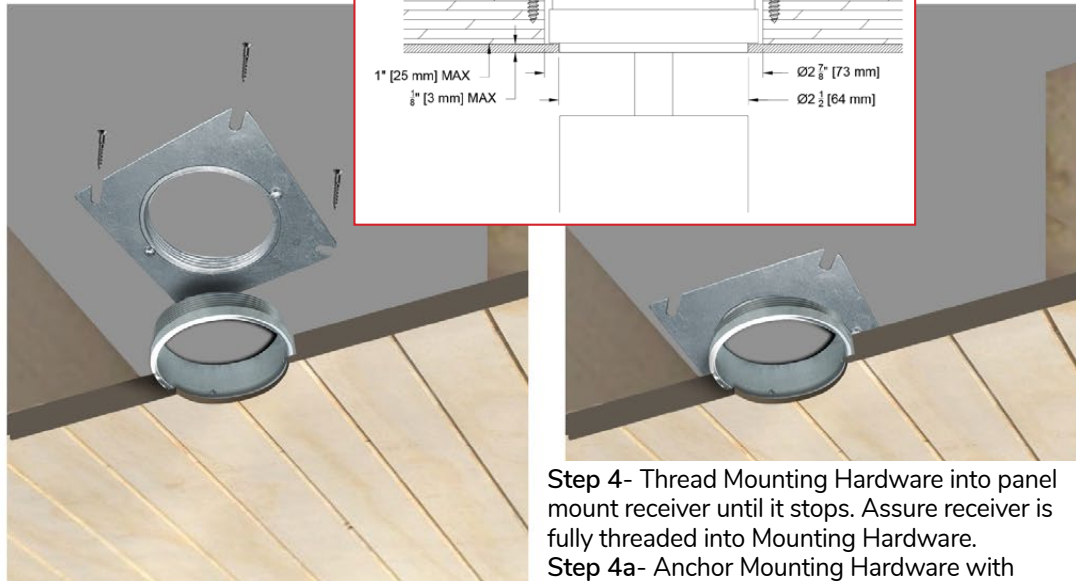
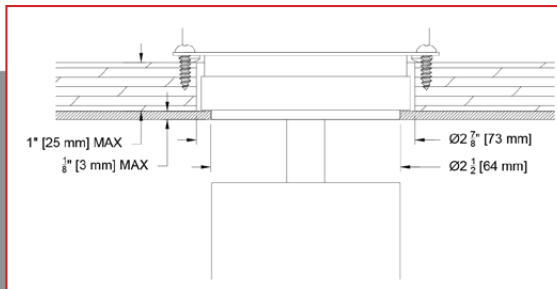

Step 3 - Cut and counter-bore millwork (see drawings above) before installing ceiling. Verify that cutouts align with panel mount receiver

Step 4- Thread Mounting Hardware into panel mount receiver until it stops. Assure receiver is fully threaded into Mounting Hardware.
Step 4a- Anchor Mounting Hardware with screws to ceiling (as shown in step 3). Back out panel mount receiver until it stops against millwork counterbore.

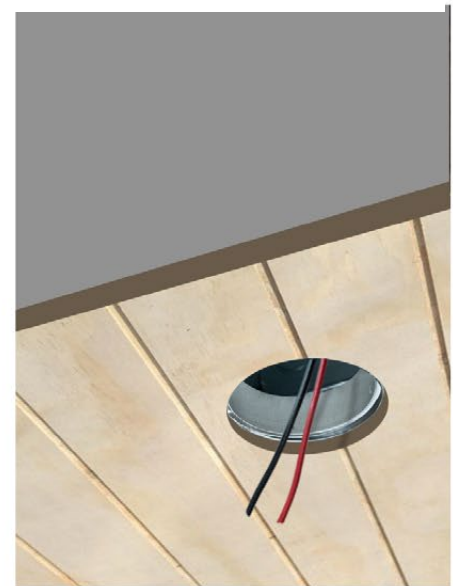

Step 5 - Attach ceiling to structure with cutouts as shown.
Step 5a- Pull LED fixture wires through ceiling aperture and make electrical connections, red to red (+) and black to black (-).

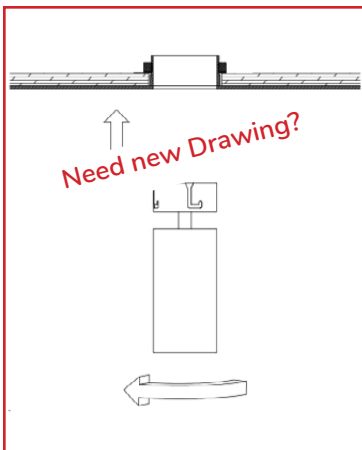

Step 6 and 7- Make sure all electrical components are working prior to inserting fixture in receiver. Align fixture j-hook slots with cleats in receiver. Push up and rotate counter-clockwise until rotation stops and fixture drops to flush position. Canopy should be flush with ceiling. Install complete.

Note: This product must be installed in accordance with the applicable installation code by a person familiar with the construction and operation of the product hazards involved. It is recommended these products be installed by a qualified electrician.



Step 1- Attach 4" diameter pancake box to structure. Pull wires from remotely located driver through knock outs in pancake box.

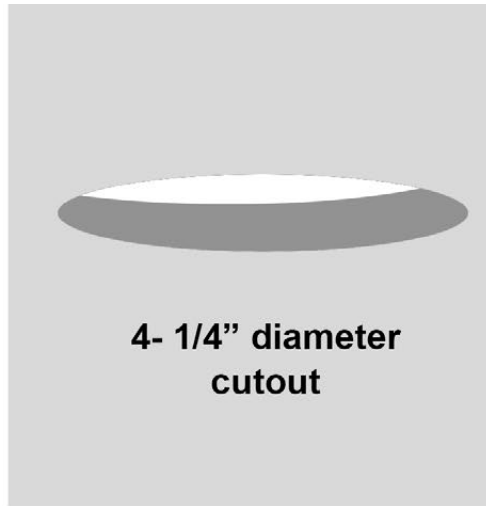

Step 2- Cut properly sized hole in GWB to fit around pancake box.



Step 3- Mount GWB over pancake box and prep/finish and paint ceiling.



Step 4- Make electrical connection – assure red to red (+) and black to black (-) . Test electrical.



Step 5- Using #8 screws included with canopy, securely fasten canopy plate to pancake box.



Screws included with anodized finish to match canopy plate



Step 6- Installation Complete

Note: This product must be installed in accordance with the applicable installation code by a person familiar with the construction and operation of the product hazards involved. It is recommended these products be installed by a qualified electrician.